



**STRONG PARTNERS.  
TOUGH TRUCKS.™**



# **HYSTER UT SERIES**

**ELECTRIC WALKIE STACKER**

**SL1.5UT / 1500KG**

**[HYSTER.COM.AU](http://HYSTER.COM.AU)**

## > OVERVIEW

# SL1.5UT

**THE HYSTER® ELECTRIC WALKIE STACKER SL1.5UT IS DESIGNED FOR PRODUCTIVITY AND FLEXIBILITY. COMBINING SIMPLE TO USE CONTROLS FOR EASY MANOEUVRABILITY, AND TECHNOLOGY FEATURES TO MAXIMISE OPERATOR PERFORMANCE.**

### Productivity

- Maintenance free AC motors
- Multi-function display with BDI and hour meter
- Handle equipped with emergency reversing button
- Auto deceleration function
- Low speed switch
- Variable speed control
- Sideways battery removal with rollers
- Mast cushioning for low-noise operation
- Built-in pressure relief valve protects from overloads
- Emergency power disconnect switch
- 240Ah traction battery
- Cold storage configuration (option)
- Narrow leg option for Australian market

### Optimum Structural Design

- Low centre of gravity enhances stability
- Full free lift mast options for low overhead clearance
- Durable plastic covers
- Adjustable balance caster wheel improves stability

## LOAD CHARTS

### Load Centre Chart

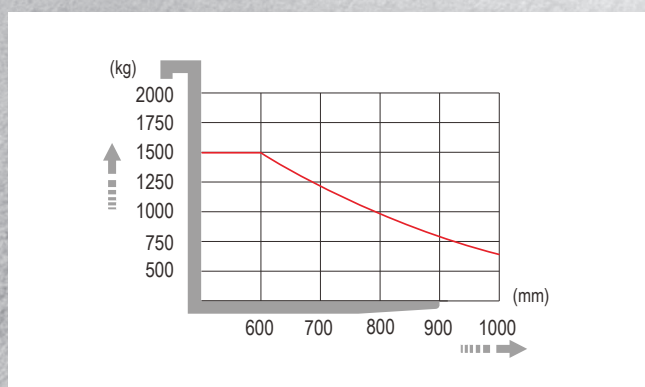

### Serviceability

- Low voltage protection setting extends the battery life
- CANbus technology
- Simple electronic components makes troubleshooting and servicing more efficient
- Hall effect sensors reduce wear and increase component life



**Handle (Standard)  
(Left & Right Handed)**



**Adjustable Straddle Legs**



**One Sided (Cold Store)**



**Two Sided (Cold Store)**

### Load Capacity Chart

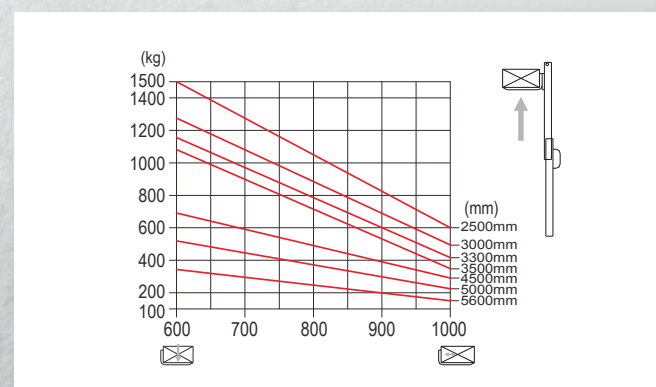

# SPECIFICATIONS <

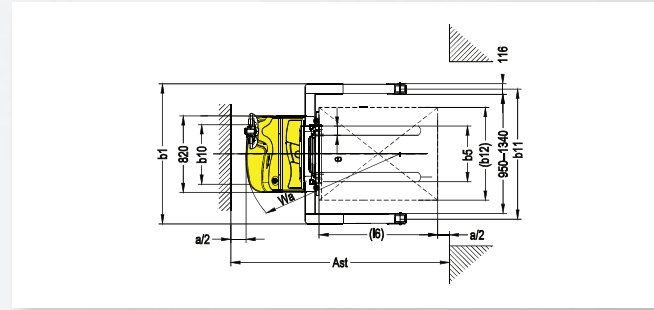
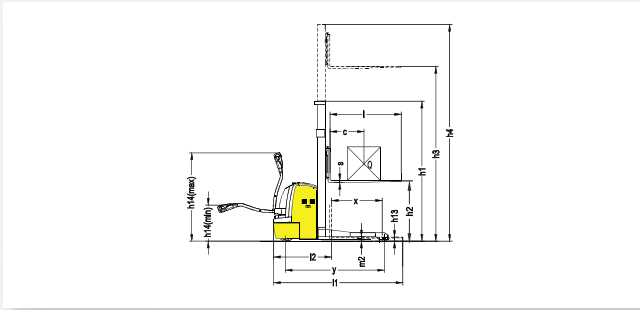

MODEL	MEASUREMENT	SL1.5UT						
Load capacity	Q (kg)	1500						
Load centre distance	c (mm)	600						
Load distance, centre of drive axle to fork	x (mm)	697						
Fork height, lowered	h13 (mm)	70						
Wheelbase	y (mm)	1420						
Axle loading, laden front/rear	kg	1440/1280						
Axle loading, unladen front/rear	kg	870/350						
Tyres		polyurethane						
Tyre size, front	mm	Φ250×70						
Tyre size, rear	mm	Φ80×84						
Additional wheels (dimensions)	mm	Φ150×60						
Wheels, number front rear (x=driven wheels)		1x+1/4						
Tread, front	b10 (mm)	520						
Tread, rear	b11 (mm)	1040-1430						
Mast height lowered	h1 (mm)	1805	2055	2205	2305	2120	2280	2480
Free lift	h2 (mm)	1300	1550	1700	1800	1570	1740	1940
Max. lift height	h3 (mm)	2500	3000	3300	3500	4500	5000	5600
Mast height extended	h4 (mm)	3025	3525	3825	4025	5080	5560	6160
Height of tiller in drive position min./max.	h14 (mm)	670/1300						
Overall length	l1 (mm)	1980						
Length to face of forks	l2 (mm)	915						
Overall width	b1 (mm)	1170-1560						
Fork dimensions	s/e/l (mm)	40/100/1070 (1150)						
Width overall forks	b5 (mm)	200-800						
Ground clearance, centre of wheelbase	m2 (mm)	35						
Aisle width for pallets 1000x1200 crossways	Ast (mm)	2480						
Aisle width for pallets 800x1200 lengthways	Ast (mm)	2465						
Turning radius	Wa (mm)	1610						
Drive motor power	kW	1.2						
Lift motor power	kW	3.0						
Sound lever at the driver's ear according to DIN12503	dB (A)	70						
Travel speed, laden/unladen	Km/h	5.8/6						
Lift speed, laden/unladen	m/s	0.11/0.15						
Lowering speed, laden/unladen	m/s	0.12/0.12						
Max. gradeability, laden/unladen	%	8/15						
Service brake		Electromagnetic						
Battery voltage, nominal capacity K5	V/Ah	24/240						
Battery weight	kg	240						
Battery dimensions l/w/h	mm	675x254x500						
Service weight (without battery)	kg	1180/1205/1220/1230/1280/1300/1320						

## SL1.5UT Power Plug Type



# HYSTER® DEALERS



Contact your nearest Hyster® Dealership  
by visiting [www.hyster.com](http://www.hyster.com)

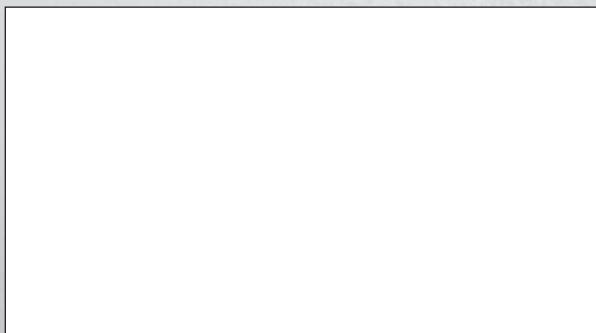

## HYSTER PACIFIC

1/23 Rowood Road, Prospect NSW 2145  
Tel: +61 (2) 9795 3800 Fax: +61 (2) 9792 8484

## HYSTER ASIA

16 Tuas Avenue 20, Singapore 638827  
Tel: +65 6863 3387 Fax: +65 6863 3349

