



**STRONG PARTNERS.
TOUGH TRUCKS.™**



HYSTER UT SERIES

ELECTRIC RIDER STACKER

S1.5UTS / 1500KG

HYSTER.COM.AU

> OVERVIEW

\$1.5UTS

THE HYSTER® ELECTRIC RIDER STACKER \$1.5UTS DELIVERS A LOW COST OF OPERATION. THESE ROBUST STACKERS CAN OPTIMISE VEHICLE LOADING AND UNLOADING OPERATIONS, AS WELL AS BOOSTING PALLET TRANSPORTATION RATES OVER SHORT AND LONG DISTANCES.

Productivity

- Maintenance free AC motor
- Multi-function display with BDI and hour meter
- Emergency reversing button
- Auto deceleration function
- Low speed switch
- Variable speed control
- Sideways battery removal is easy to maintain
- Mast cushioning for low-noise operation
- Built-in pressure relief valve protects from overloads
- Emergency power disconnect switch
- Cushioned ergonomic platform
- Cold store configuration (option)

Optimum Structural Design

- Low centre of gravity enhances stability
- Full free lift mast options for low overhead clearance
- Durable plastic covers
- Adjustable balance casters improve stability

Serviceability

- Low voltage protection setting extends the battery life
- CANbus technology
- Simple electronic components makes troubleshooting and servicing more efficient
- Hall effect sensors reduce wear and increase component life



**Handle (Standard)
(Left & Right Handed)**

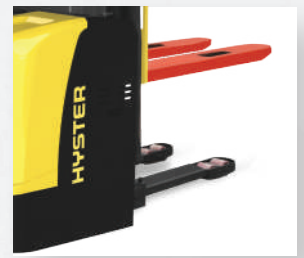

**Fork Lengths to Suit All
Applications**



One Sided (Cold Store)



Two Sided (Cold Store)

LOAD CHARTS

Load Centre Chart

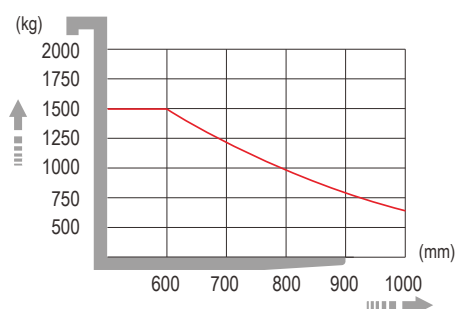

Load Capacity Chart

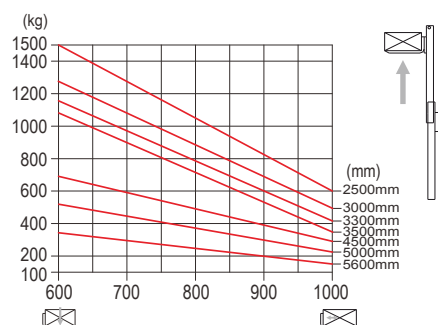

SPECIFICATIONS AND DIMENSIONS <

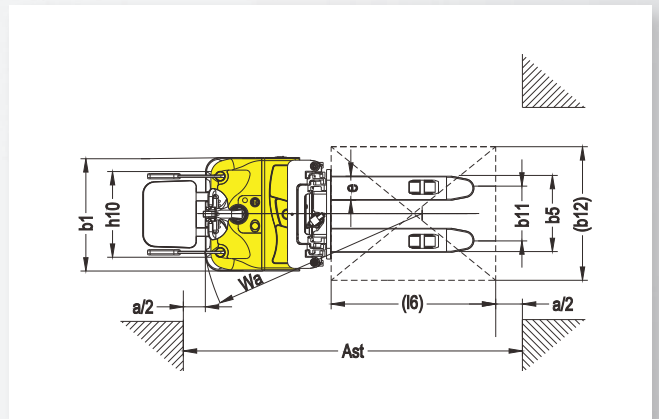
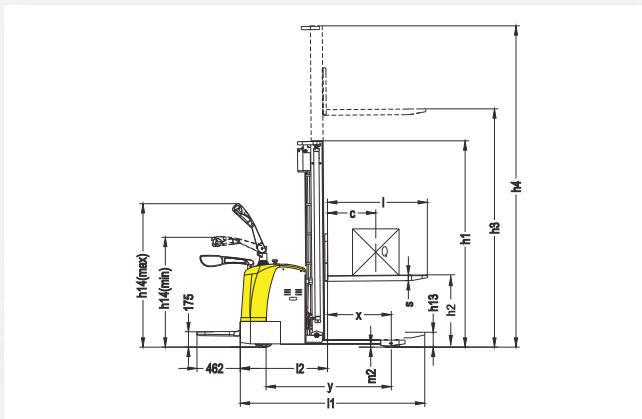

MODEL	MEASUREMENT	S1.5UTS						
Load capacity/rated load	Q (kg)	1500						
Load centre distance	c (mm)	600						
Load distance, centre of drive axle to fork	x (mm)	672						
Wheelbase	y (mm)	1378						
Fork height, lowered	h13 (mm)	85						
Tyre size, front	mm	Φ250x70						
Tyre size, rear	mm	Φ80x84						
Additional wheels (dimensions)	mm	Φ150x60						
Wheels, number front rear (x=driven wheels)		1x+2/4						
Height, mast lowered	h1 (mm)	1735	1985	2135	2235	2050	2410	2410
Free lift (option 2500-3500mm)	h2 (mm)	0	0	0	0	1570	1940	1940
Max. Lift height	h3 (mm)	2590	3090	3390	3590	4590	5090	5690
Height, mast extended	h4 (mm)	2955	3455	3755	3955	5030	5510	6110
Height of tiller in drive position min./max.	h14 (mm)	1150/1450						
Overall length	l1 (mm)	2020/2100						
Length to face of forks	l2 (mm)	950						
Overall width	b1 (mm)	850						
Fork dimensions	s/e/l (mm)	60/180/1070 (1150)						
Width overall forks	b5 (mm)	570/695						
Aisle width for pallets 800x1200 lengthways	Ast (mm)	2515						
Turning radius	Wa (mm)	1655						
Steer Motor		Mechanical				Electronic		
Drive motor power	kW	1.2				1.5		
Lift motor power	kW	3.0						
Sound level at the driver's ear according to DIN12503	dB (A)	70						
Travel speed, laden/unladen	Km/h	6.5/6.7						
Lift speed, laden/unladen	m/s	0.11/0.14						
Lowering speed, laden/unladen	m/s	0.12/0.12						
Battery voltage, nominal capacity K5	V/Ah	24/240				24/300 (option)		
Battery weight	kg	220				260		
Battery dimensions l/w/h	mm	675x254x500				675x254x540 (option)		
Service weight (with battery)	kg	1240/1270/1285/1490/1520/1560/1580 ¹						

S1.5UTS Power Plug Type





HYSTER® DEALERS

Contact your nearest Hyster® Dealership
by visiting www.hyster.com.au

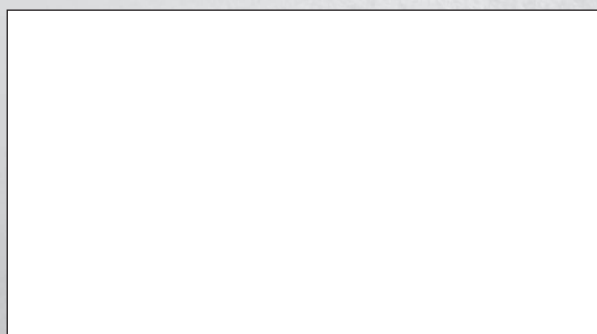

HYSTER PACIFIC

1 Bullecourt Avenue, Milperra NSW, Australia 2214
Tel: +61 (2) 9795 3800 Fax: +61 (2) 9792 8484
hyster.com/pacific/en-au

HYSTER ASIA

16 Tuas Avenue 20, Singapore 638827
Tel: +65 6863 3387 Fax: +65 6863 3349
hyster.com/asia/en-sg



/Hysterasiapacific



HysterJAPIC



Hyster Asia-Pacific