



**STRONG PARTNERS.
TOUGH TRUCKS.™**



HYSTER

STAND-ON MOVING MAST REACH TRUCK

R2.00-3.00EX 2 / 2000-3000KG

HYSTER.COM

FEATURES

1 EXCELLENT ERGONOMICS



The design is centred around enhanced comfort and intuitive operation. The operator compartment has been carefully designed to maximise efficiency, while reducing strain and fatigue on the driver, resulting in improved load handling and increased overall productivity.

2 EFFICIENT ELECTRIC CONTROLS



The inclusion of an AC induction traction motor, controlled by Field Effect Transistor (FET) inverter, enables smooth, step-less acceleration and deceleration. In addition, this technology provides powerful regenerative braking, to reduce wear and prolong brake service life. Inching control is also optimised, when lifting and lowering, due to the AC motor and large low-speed range of the lift valve.

3 IMPRESSIVE MANOEUVRABILITY



A combination of factors including power-on-demand steering, small diameter steering wheel and increased aisle space - when turning or stacking - using the Aisle Width Control technology; allow the truck to excel in tight spaces with limited driver effort.



> Design Overview

The Hyster® R2.00-3.00EX 2 range has been designed central to your business and operator's needs:

- Simple and efficient to use
- Greater control and manoeuvrability
- Comfortable and intuitive to operate
- Additional driver safety features and alerts
- Comprehensive display
- Fast and easy to service
- Maximised productivity
- Low cost of ownership

> The Range

Available in three different capacities:

- R2.00EX 2 – 2,000 Kg
- R2.50EX 2 – 2,500 Kg
- R3.00EX 2 – 3,000 Kg



4 RELIABLE, PRODUCTIVE & EFFICIENT

The use of high quality and robust components, help deliver a reliable operation, with limited wear and tear. The inclusion of the AC motor, turning control function and newly designed hydraulic equipment enable energy efficiency and up-time to be maximised. A superb suspension system also allows for faster work cycles and greater productivity.

5 OPTIMUM CONTROL ON CORNERS & SLOPES

Torque in the drive motor is carefully controlled to maintain appropriate cornering speeds. Thus, improving stability on corners, while contributing to energy efficiency, by limiting the operator's ability to accelerate excessively. Moreover, the truck can maintain a constant speed on downward slopes, when in the neutral position.

6 OPERATIONAL ALERTS

The machine produces a buzzing sound to warn the operator if they accelerate, brake or turn too suddenly. The point at which the operational alerts are engaged can be adjusted to suit each individual application; maintaining efficiency on all site types, whilst limiting poor driver practices.

> Low Cost of Ownership

The use of high quality and robust components within the range deliver a reliable operation with limited wear and tear. The trucks have been designed to maximise uptime, delivering high productivity, while remaining economically and environmentally efficient. Maintenance costs and requirements are further reduced by simple, readily available, cost effective replacement parts. Additionally, serviceable parts have been designed to allow for fast and easy access.

> Cold Store Protection Options

❄ Cold store freeze proof options

- Minus 35°C or 45°C

❄ Fishery cold storage option

- Minus 35°C

> SPECIFICATIONS

Distinguishing Marks	1.1	Manufacturer		HYSTER	HYSTER	HYSTER
	1.2	Model designation		R2.00EX 2	R2.50EX 2	R3.00EX 2
	1.5	Rated capacity	Kg	2000	2500	3000
	1.4	Operator Type		Stand	Stand	Stand
	1.6	Load center	mm	500	500	500
	1.9	Wheelbase	Y (mm)	1525	1700	1800
Weight	2.1	Unladen Weight	Kg	2960	3010	3200
	2.2	Axle loading (reach in), unladen front/rear	Kg	960 / 2000	910 / 2100	995 / 2270
	2.3	Axle loading (reach out), unladen front/rear	Kg	1300 / 1660	1225 / 1785	1405 / 1860
Tyres, chassis	3.1	Tyre Type		Solid	Solid	Solid
	3.2	Tyre size, front		267x114U	267x135U	267x135U
	3.3	Tyre size, rear		394x152R	394x152R	394x152R
	3.4	Caster size		204x74R	204x74R	204x74U
	3.5	Number of wheels, front / drive / caster		2 / 1 / 2	2 / 1 / 2	2 / 1 / 2
	3.6	Tread, front	b10 (mm)	1080	1075	1075
	3.7	Tread, rear	b11 (mm)	725	725	725
Dimensions	4.1	Tilt of mast / fork carriage , forward α / back β	degrees	3 / 5	3 / 5	3 / 5
	4.2	Height of mast, lowered	h1 (mm)	1995	1995	2020
	4.3	Free lift	h2 (mm)	150	150	155
	4.4	Lift height	h3 (mm)	3000	3000	3000
	4.5	Height of mast, extended	h4 (mm)	3950	3950	3955
	4.7	Height to top of overhead guard	h6 (mm)	2270	2270	2270
	4.19	Overall length (with forks)	l1 (mm)	2210	2210	2310
	4.2	Length to face of forks	l2 (mm)	1290	1290	1392
		Length to top of outrigger	l3 (mm)	1915	2090	2190
	4.21	Overall width	b1 (mm)	1190	1210	1210
		Outrigger width	b2 (mm)	1190*	1190*	1230
	4.22	Fork dimensions	s / e / l (mm)	40 / 122 / 920	40 / 122 / 920	45 / 122 / 920
	4.23	Fork carriage (hook)	Fork carriage DIN 15173. Class, A / B	2A	2A	3A
	4.24	Fork carriage width	b3 (mm)	838	838	838
	4.25	Distance between fork-arms min / max	b5 (mm)	250 / 780	250 / 780	250 / 780
	4.28	Stroke (Reach distance)	l4 (mm)	665	840	840
		Height Outrigger	h7 (mm)	290	290	290
	4.32	Ground clearance at centre of wheelbase	m2 (mm)	90	90	90
	4.35	Turning radius	Wa (mm)	1775	1950	2045
		Front overhang	S (mm)	190	190	190
4.33	Minimum right-angled aisle width	L1100 x W1100 pallet	1810	1900	1950	
4.34	Right-angled stacking aisle width	L1100 x W1100 pallet	2760	2760	2850	
4.42	Step height	K (mm)	320	320	320	
Performance Data	5.1	Travel speed laden / unladen	km / h	9 / 9.5	9 / 9.5	9 / 9.5
	5.2	Lifting speed laden / unladen	m / s	0.315 / 0.5	0.295 / 0.5	0.245 / 0.415
	5.3	Lowering speed laden / unladen	m / s	0.51 / 0.56	0.51 / 0.56	0.54 / 0.49
	5.7	Gradeability, laden / unladen @ 1.5 km/h	%	13 / 23	13 / 23	11 / 23
	5.10	Service brake, mechanical / hydraulic / electric / pneumatic		Mechanical	Mechanical	Mechanical
	Foot / hand / deadman brake		Deadman	Deadman	Deadman	
Power		Drive motor control output		FET inverter	FET inverter	FET inverter
	6.1	Rated output (60 min rating)	kW	5.2	5.2	5.2
		Hoist motor control method		FET inverter	FET inverter	FET inverter
	6.2	Rated output (5 min rating)	kW	9.6	9.6	9.6
	6.4	Battery voltage / nominal capacity K5	(V) / (Ah)	48 / 312	48 / 312	48 / 370
	6.5	Battery weight	kg	520	520	585
		Steering motor control output		FET chopper	FET chopper	FET chopper
6.6	Rated output (60 min rating)	kW	0.3	0.3	0.3	

*Note: Outrigger width (b2) is 1340 mm for 6500-8000 mm masts

TRUCK DIMENSIONS

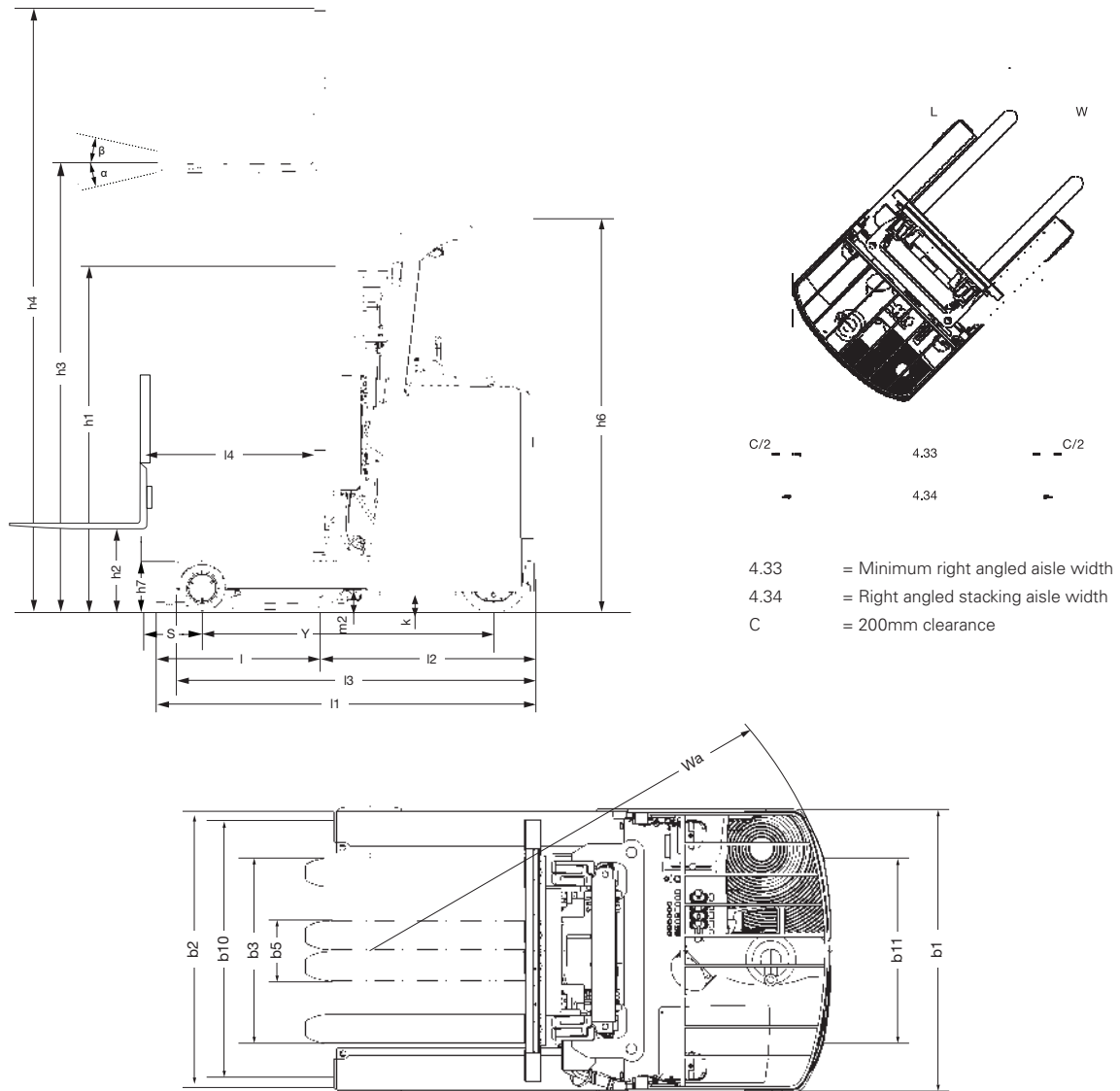

- 4.33 = Minimum right angled aisle width
- 4.34 = Right angled stacking aisle width
- C = 200mm clearance

Aisle width, pallet length: L, pallet width: W (mm) This table below indicates the value during AWC (small turning radius control) stacking mode.

Model	Mast	Battery	Intersecting (IA) and Right-angle aisle width					Right-angle stacking (SA) aisle width**						
			L	800	1,000	1,000	1,000	1,100	L	800	1,000	1,000	1,000	1,100
			W	1,100	1,000	1,000	1,200	1,100	W	1,100	1,000	1,000	1,200	1,100
R2.00EX 2	2 STG LFL	*312/370Ah	1,800	1,800	1,810	1,820	1,810	2,300	2,450	2,470	2,490	2,560		
		440Ah	1,800	1,800	1,810	1,830	1,820	2,380	2,530	2,550	2,580	2,650		
		476Ah	1,800	1,800	1,810	1,830	1,820	2,380	2,530	2,550	2,580	2,650		
	3 STG FFL	*312/370Ah	1,800	1,800	1,810	1,830	1,820	2,380	2,530	2,550	2,580	2,650		
		440Ah	1,800	1,800	1,810	1,830	1,820	2,380	2,530	2,550	2,580	2,650		
		476Ah	1,800	1,800	1,810	1,830	1,820	2,400	2,560	2,580	2,600	2,670		
R2.50EX 2	2 STG LFL	*312/370Ah	1,890	1,890	1,900	1,910	1,900	2,320	2,450	2,470	2,500	2,560		
		440Ah	1,900	1,890	1,900	1,910	1,910	2,380	2,530	2,550	2,580	2,650		
		476Ah	1,900	1,890	1,900	1,910	1,910	2,380	2,530	2,550	2,580	2,650		
	3 STG FFL	*312/370/440Ah	1,900	1,890	1,900	1,910	1,910	2,380	2,530	2,550	2,580	2,650		
		476Ah	1,900	1,890	1,900	1,920	1,910	2,410	2,560	2,580	2,600	2,670		
R3.00EX 2	2 STG LFL	*370/440/476Ah	1,950	1,940	1,950	1,960	1,950	2,400	2,540	2,560	2,590	2,650		
	3 STG FFL	*370/440/476Ah	2,100	2,100	2,110	2,120	2,120	2,470	2,630	2,650	2,670	2,740		

* Standard model
 ** the aisle width is for loading work at right angles regulated by the JIS D 6202

> FEATURES

> OPERATOR COMPARTMENT OVERVIEW

- Low step height, 320 mm
 - » Reduces driver fatigue when stepping on and off the truck
- Unique suspension system
 - » Parallel link structure with suspension lock mechanism, helps to deliver smooth, stable and comfortable driving conditions
- Formed rubber floor mat
 - » Aids operator comfort by isolating the driver from unwanted noise and vibration
- Adjustable hip support, high back support and moulded elbow pad to optimise driver comfort
- Comprehensive LCD full function display with programmable input options and anti-glare visor
 - » Digital clock, odometer, hour meter, parking brake status, battery discharge indicator, password entry for 10 ID's, 3 user selectable performance modes and real time service diagnostics

> DESIGNED FOR SAFETY

- Operator Presence System (OPS)
 - » Both travel and load handling operations are disabled when the driver vacates the operator compartment, to help prevent unauthorised operation
- Wide outrigger, for improved stability on the high lift mast
- Robust overhead guard provides protection from falling inventory

> OPTIONAL FEATURES

- Charging control options
 - » Auto, reverse and equalising charging
- Solenoid disk brake with anti-skid and traction control
- Non-marking solid and urethane tyre options
- Multiple light configuration options
 - » Rotating LED amber (with high or low mounting)
 - » Working lights, Blue lights, safety laser
- Multiple fishery and cold store options
- Optional front wheel brake anti skid control
 - » If the drive tyres were to slip, the front wheel brakes would assist, this control prevents the tyres from locking, in addition to providing maximum brake force



Ergonomic Operator Compartment & Intuitive Controls

MAST AND CAPACITY INFORMATION ◀

Mast Type	Max fork height (mm)	Lowered height (mm)	Overall Extended Height	Free lift	Capacity (kg)			
					@ 500mm LC	@ 600mm LC	@ 500mm LC	@ 600mm LC
					R2.00EX 2		R2.50EX 2	
2 STG LFL	2,545	1,995	3,450	150	2,000	1,750	2,500	2,190
	2,745	1,995	3,650	150	2,000	1,750	2,500	2,190
	3,045	1,995	3,950	150	2,000	1,750	2,500	2,190
	3,345	2,170	4,250	150	2,000	1,750	2,500	2,190
	3,545	2,270	4,450	150	2,000	1,750	2,500	2,190
	3,745	2,420	4,650	150	2,000	1,750	2,500	2,190
	4,045	2,620	4,950	150	2,000	1,750	2,500	2,190
	4,345	2,770	5,250	150	1,950	1,700	2,450	2,140
	4,545	2,870	5,450	150	1,900	1,660	2,400	2,100
	5,045	3,120	5,950	150	1,850	1,620	2,300	2,010
	3 STG FFL	3,830	1,870	4,735	970	2,000	1,740	2,500
4,130		1,970	5,035	1,070	2,000	1,740	2,500	2,180
4,340		2,040	5,245	1,140	1,900	1,660	2,400	2,100
4,580		2,120	5,485	1,220	1,800	1,570	2,300	2,010
5,030		2,270	5,935	1,370	1,700	1,480	2,200	1,920
5,330		2,370	6,235	1,470	1,650	1,440	2,150	1,880
5,680		2,520	6,585	1,620	1,600	1,390	2,050	1,790
6,030		2,720	6,935	1,820	1,500	1,310	1,900	1,660
6,500		2,950	Ⓟ	Ⓟ	Ⓟ	Ⓟ	Ⓟ	Ⓟ
7,000		3,115	Ⓟ	Ⓟ	Ⓟ	Ⓟ	Ⓟ	Ⓟ
7,500		3,280	Ⓟ	Ⓟ	Ⓟ	Ⓟ	Ⓟ	Ⓟ
8,000		3,450	Ⓟ	Ⓟ	Ⓟ	Ⓟ	Ⓟ	Ⓟ

Mast Type	Max fork height (mm)	Lowered height (mm)	Overall Extended Height	Free lift	Capacity (kg)	
					@ 500mm LC	@ 600mm LC
					R3.00EX 2	
2 STG LFL	2,550	2,020	3,455	155	3,000	2,620
	2,750	2,020	3,655	155	3,000	2,620
	3,050	2,020	3,955	155	3,000	2,620
	3,350	2,170	4,255	155	3,000	2,620
	3,550	2,270	4,455	155	3,000	2,620
	3,750	2,420	4,655	155	3,000	2,620
	4,050	2,620	4,955	155	3,000	2,620
	4,350	2,770	5,255	155	2,950	2,580
	4,550	2,870	5,455	155	2,900	2,540
	5,050	3,120	5,955	155	2,800	2,450
	3 STG FFL	3,820	1,870	4,725	925	3,000
4,120		1,970	5,025	1,025	3,000	2,620
4,330		2,040	5,235	1,095	3,000	2,620
4,570		2,120	5,475	1,175	2,950	2,580
5,020		2,370	5,925	1,425	2,700	2,360
5,320		2,520	6,225	1,575	2,600	2,270
5,720		2,720	6,625	1,775	2,200	1,920
6,020		2,870	6,925	1,925	2,100	1,840

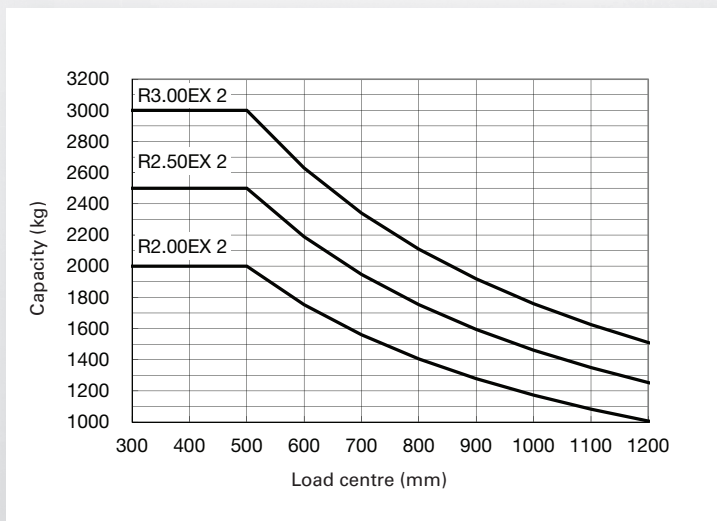

All masts have 3 degrees forward tilt and 5 degrees backward tilt

1. MFH: Maximum Fork Height (MFH) shown with the load. Add 5mm without load.
2. OLH: Overall Lowered Height (OLH) includes Free Lift.
3. OEH: Overall Extended Height (OEH) shown with standard 900 mm load backrest and without load.
4. FL: Free Lift (FL)
5. Capacity (kg) with standard carriage

	Cold Storage		Fishery Cold Storage
	-35 deg	-45 deg	-35 deg
Additional front axle seal	x	x	✓
Anti-cold rust proof paint	✓	✓	✓
Anti-cold Hyd oil (T15)	✓	✓	✓
Anti-cold Hoses	x	✓	x

HYSTER® DEALERS



Contact your nearest Hyster® Dealership
by visiting www.hyster.com.au



HYSTER PACIFIC

Locked Bag 1126, Milperra NSW 2214
Tel: +61 (2) 9795 3800 Fax: +61 (2) 9792 8484
hyster.com/pacific/en-au

HYSTER ASIA

16 Tuas Avenue 20, Singapore 638827
Tel: +65 6863 3387 Fax: +65 6863 3349
hyster.com/asia/en-sg



[/Hysterasiapacific](https://www.facebook.com/Hysterasiapacific)



[HysterJAPIC](https://www.linkedin.com/company/HysterJAPIC)



[Hyster Asia-Pacific](https://www.youtube.com/HysterAsia-Pacific)