



# MR SERIES

BROCHURE

MR14-16HD  
Reach Truck

---

1,400–1,600kg



# Reach Higher

As your customers demand more from you, you should be able to expect more from your reach trucks. The Yale® MR series delivers more.

- More flexibility with two models and six capacities from 1,400kg to 1,600kg and lift heights up to 11.4m
- More choice with three battery compartment sizes available to match your application
- More productivity with higher travel, lift and lower speeds
- More comfort with ergonomic controls and enhanced visibility
- Greater efficiency with easier serviceability and lower costs of ownership

## RESPONSIVE PERFORMANCE

To move more loads per hour, fast cycle times are essential. That's why we've increased the MR's mast speed to 0.8 metres per second with masts lifting up to 11.4m.

## PRECISE PERFORMANCE

But, power without control is not efficient. From adjustable speed reduction on cornering, auto regenerative braking and creep speed select, the MR series puts your operator in total control.

# Take Control

The more time your operator spends in the operator compartment, the more productive they will be, which is why we have designed the operator compartment around their needs.

## FOCUSED THINKING

For operators, constantly having to adjust their line of sight is time consuming, which is why the MR series models feature high visibility masts and overhead guards, which offer operator protection whilst offering excellent upward and all round visibility, without any compromise to its strength or security.

## COMFORTABLY BETTER

The low, wide step, integrated grab handles and an adjustable steering column support easy access. A full suspension adjustable seat with integral lumbar support dramatically reduces whole body vibration; while wide spaced floor pedals provide increased leg room and a more comfortable operating position.

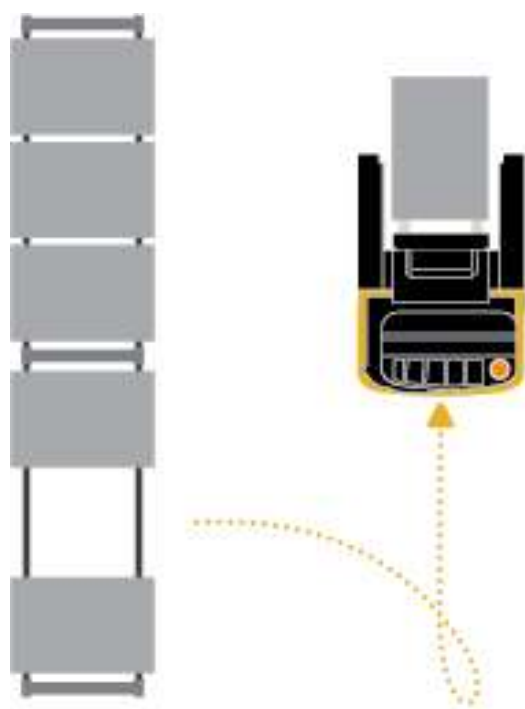

### 360° STEERING

Drive wheel rotates without stopping when manoeuvring within the aisle.

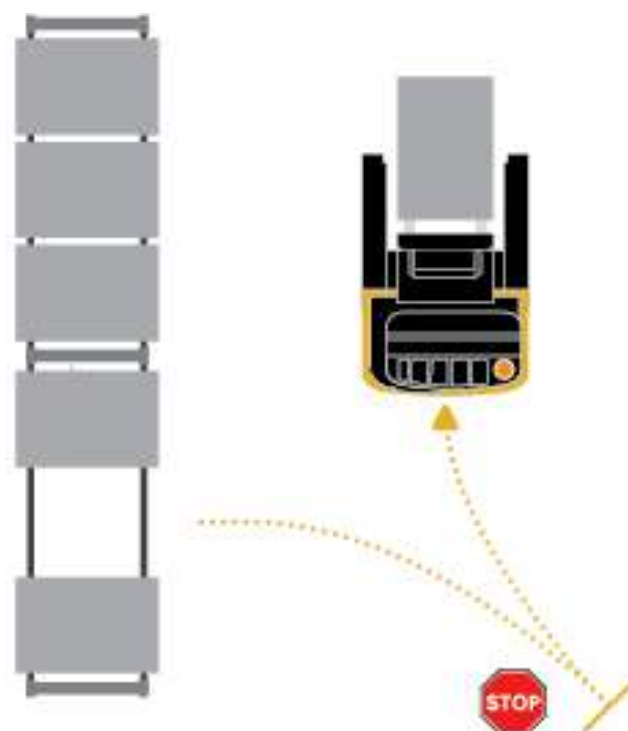

### 180° STEERING

Truck has to come to a stop and direction of travel selected manually by operator.

## THINK ERGONOMICS



- Designed for the operator
- High visibility
- Easy access
- Spacious cabin
- Adjustable full suspension seat

# Made to Perform. Built to Last.



→ MR Series 1,400-1,600kg



Heavy-duty mast design delivers high residual capacities and stable load handling

High visibility mast provides outstanding upward and all round visibility

Integrated grab handle on the left hand on the overhead guard post and for the right hand underneath the arm rest

AccuTouch mini-lever module:

- Maximum hydraulic control operator familiarity
- Additional function buttons integrated into the adjustable armrest

Touch screen display provides PIN access, height preselect, creep speed selection



The low and wide step gives easy access

Swing open door and fast-release floor plate  
→ 7,500 hours transmission oil changes

TRUCK DIMENSIONS

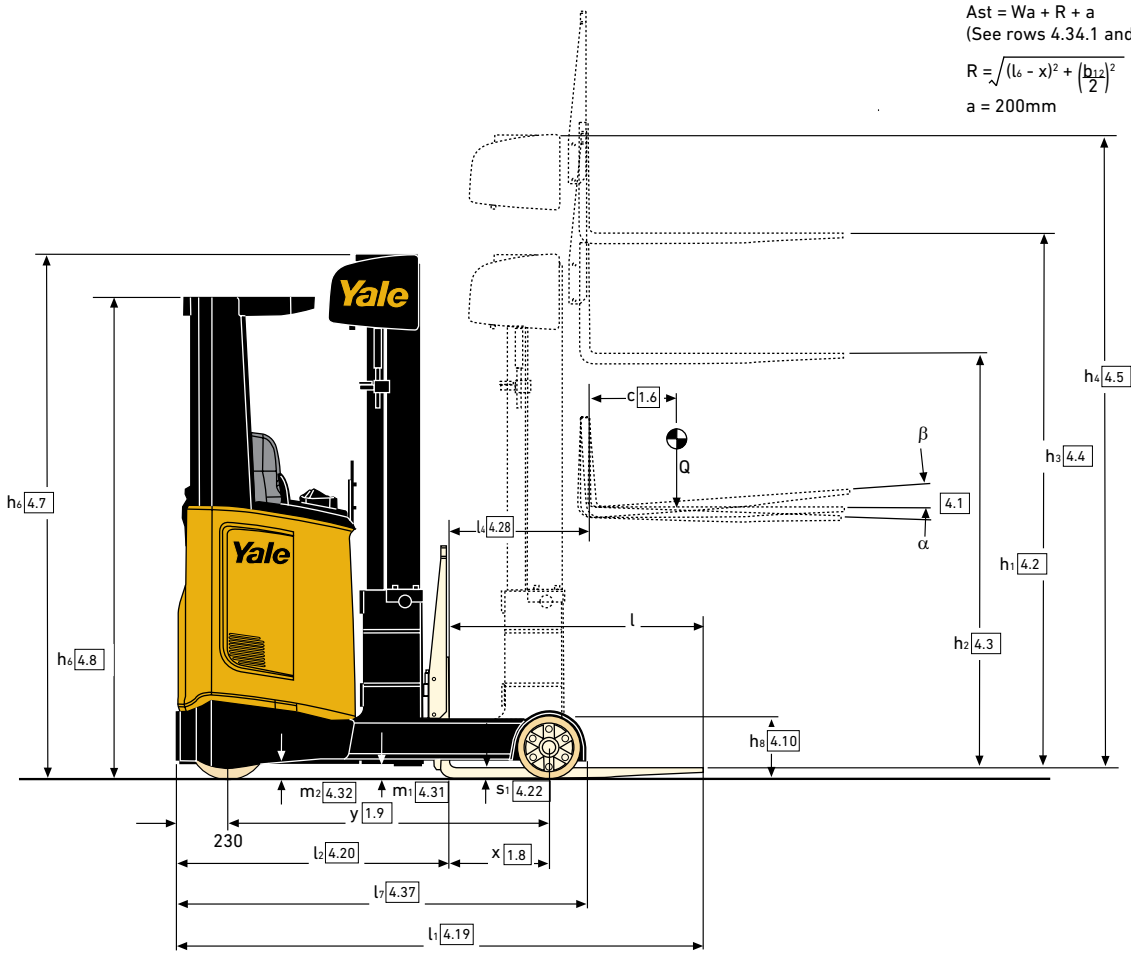

$Ast = Wa + R + a$   
 (See rows 4.34.1 and 4.34.2)  
 $R = \sqrt{(l_6 - x)^2 + \left(\frac{b_{12}}{2}\right)^2}$   
 $a = 200\text{mm}$

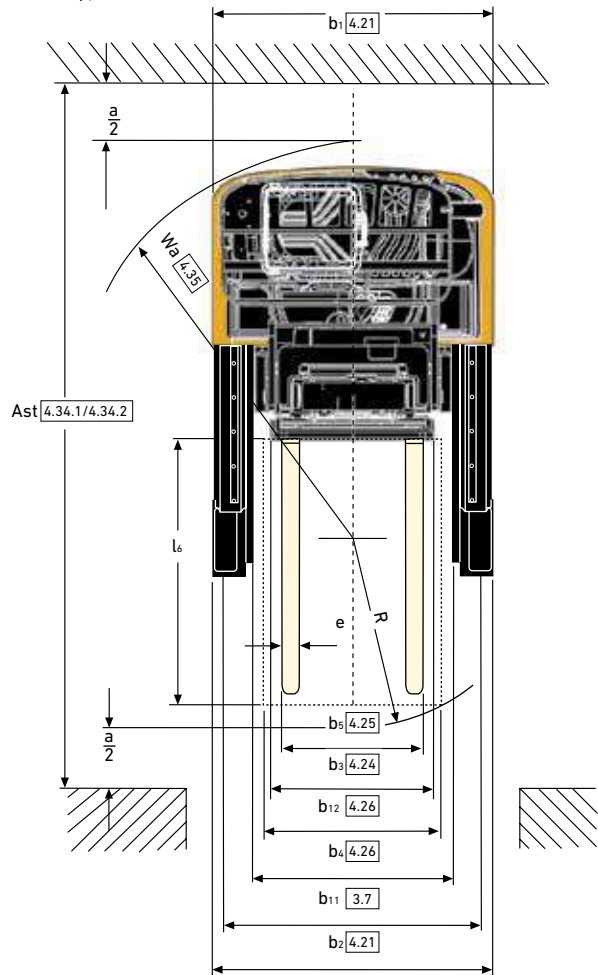
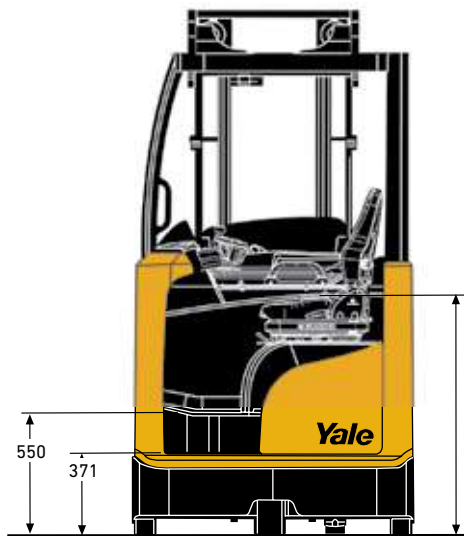

# MR14-16

## Reach Truck

The Yale® MR Series Reach Truck features three piece design which is the same for all different models. The main differentiators between the models are the wheelbase and the truck width.

### **OVERHEAD GUARD**

The one piece welded overhead guard gives a good visibility to all directions. The two different pillar profiles give adequate stiffness strength, with a minimum impact on visibility.

### **OPERATOR COMPARTMENT**

The operator compartment structure is a one piece welded structure developed for long term durability. It is bolted on the frame having boxed bottom part for stiff compartment and reduced vibrations to the operator.

The step with grip profile has a maximum depth of 130mm and low height of 371mm.

### **FRAME**

Completely welded base frame is available with 3 different battery compartment sizes.

### **SEATS**

Full-suspension seat with adjustment for operator weight, fore/aft position and backrest angle.

### **STEERING CONSOLE**

The steering console is one hand adjustable for length to provide the optimum position for the operator. It has a 10° incline in the direction of the operator, as a result of the length adjustment the height will increase with 17.5mm from the max in to max out position. This will ease the in- and egress of the operator even in extracted steering column position. To improve operators left arm ergonomics the steering column is slightly 3° angled anti clockwise.

### **STEERING SYSTEM**

The steering system is a fully fly-by-wire system. The steer wheel input and the steer motor output are connected to the controller and managed by the VCM. The steer positioning sensors provide feedback of the actual steer position. The standard steering has a 180° steer angle, a 360° option is available and enabled by the VCM software. Speed reduction on cornering is automatic and can be adjusted.

### **FOOT PEDALS**

Low resistant foot pedals positioned on the slightly inclined (13°) floor plate to improve the pedal operation ergonomics. The useful operator floor space is increased with the pedal layout is divided over the available width. The operator presence switch is slightly rotated to the mid line off the operator seat to improve operator left foot position. The thick (min. 8mm) one piece floor mat absorbs vibrations and noise out of the motor compartment.

### **DASH DISPLAY**

The display is integrated in the dashboard in front of the operator. In this location the display is easy to read and to operate. The standard display utilises the proven display design from Yale ECB trucks. An optional industry first premium touch screen display allows operators to be in full control of the truck at all times.

### **VEHICLE CONTROL MANAGER**

The Vehicle Control Manager (VCM) is the central module of the truck and it is linked to the truck modules via Dual CANbus system to increase reliability and truck dependability. With this proven technology used in the automobile sector point to point wiring is greatly reduced.

### **HYDRAULIC CONTROLS**

The Hydraulic controls are integrated in ergonomic sliding armrest under driver's right hand. The standard controls is proven AccuTouch™ mini-levers module with separate horn and direction switches.

### MASTS

A three stage full free lift mast incorporates unique Yale designed profiles that reduce the total mast channel width. Lift cylinders position optimised to increase operator visibility. Cross members are not in direct line of visibility for critical heights. The stiff and robust mast carriage is a welded construction made out of two lateral plates of 30mm and several cross bars and base plate of 12mm thick to create an open boxed frame.

### MOTORS

The drive motor remains in a fixed position to avoid flexing of the power cables.

Optimised acceleration and travel speed performance delivers high load handling efficiency productivity. Easy access through swing-open motor compartment door. The steering motor also uses AC technology and the gear on gear arrangement provides a positive mesh for precise steering control. On power-up the drive wheel is automatically centred. A removable plate allows access to the drive tyre/ gear reducer for servicing. The motor compartment including the hoist motor is ventilated.



### MR14 TRUCK DIMENSIONS FOR BATTERIES

DISTINGUISH MARK	1.1		MR14					
	1.8	Load distance, centre of drive axle to fork	x (mm)	402	330	258		
	1.9	Wheelbase	y (mm)	1400				
WEIGHTS	2.1	Service weight	kg	3112	3320	3495	3541	
	2.3	Axle loading, unladen front/rear	kg	1977 / 1135	2032 / 1289	2055 / 1440	2084 / 1457	
	2.4	Axle loading fork advanced, laden front/rear	kg	682 / 3830	800 / 3921	885 / 4010	914 / 4027	
	2.5	Axle loading fork retracted, laden front/rear	kg	1778 / 2735	1760 / 2960	1711 / 3184	1741 / 3201	
DIMENSIONS	4.19	Overall length	l1 (mm)	2379	2451	2523		
	4.20	Length to face of forks	l2 (mm)	1229	1301	1373		
	4.28	Reach distance	l4 (mm)	585	513	441		
	4.34.1	Aisle width for pallets 1000mm x 1200mm crossways	Ast (mm)	2718	2771	2828	2826	
	4.34.2	Aisle width for pallets 800mm x 1200mm lengthways	Ast (mm)	2764	2829	2895		
4.35	Turning radius	Wa (mm)	1671					
ELECTRIC-ENGINE	6.3	Battery according to DIN 43531/35/36 A, B, C, no		C	C "Super"	C "Super"	C	C "Super"
	6.4	Battery voltage/nominal capacity K5	(V) / (Ah)	48 / 420	48 / 465	48 / 620	48 / 700	48 / 775
	6.5	Battery weight	kg	750	950	1119	1165	

### MR16 TRUCK DIMENSIONS FOR BATTERIES

DISTINGUISH MARK	1.1		MR16					
	1.8	Load distance, centre of drive axle to fork	x (mm)	452	380	308		
	1.9	Wheelbase	y (mm)	1450				
WEIGHTS	2.1	Service weight	kg	3162	3360	3371	3546	3592
	2.3	Axle loading, unladen front/rear	kg	2018 / 1144	2069 / 1291	2077 / 1294	2103 / 1443	2133 / 1459
	2.4	Axle loading fork advanced, laden front/rear	kg	601 / 4162	714 / 4246	721 / 4250	810 / 4336	839 / 4352
	2.5	Axle loading fork retracted, laden front/rear	kg	1853 / 2909	1825 / 3135	1832 / 3139	1779 / 3367	1809 / 3383
DIMENSIONS	4.19	Overall length	l1 (mm)	2379	2451	2523		
	4.20	Length to face of forks	l2 (mm)	1229	1301	1373		
	4.28	Reach distance	l4 (mm)	635	563	491		
	4.34.1	Aisle width for pallets 1000mm x 1200mm crossways	Ast (mm)	2731	2781	2834		
	4.34.2	Aisle width for pallets 800mm x 1200mm lengthways	Ast (mm)	2767	2830	2896		
4.35	Turning radius	Wa (mm)	1718					
ELECTRIC-ENGINE	6.3	Battery according to DIN 43531/35/36 A, B, C, no		C "Super"	C	C "Super"	C	C "Super"
	6.4	Battery voltage/nominal capacity K5	(V) / (Ah)	48 / 465	48 / 560	48 / 620	48 / 700	48 / 775
	6.5	Battery weight	kg	750	939	950	1119	1165

### MR16HD TRUCK DIMENSIONS FOR BATTERIES

DISTINGUISH MARK	1.1		MR16HD					
	1.8	Load distance, centre of drive axle to fork	x (mm)	308				293
	1.9	Wheelbase	y (mm)	1450				
WEIGHTS	2.1	Service weight	kg	4038	4049	4224	4270	
	2.3	Axle loading, unladen front/rear	kg	2417 / 1621	2424 / 1625	2428 / 1796	2457 / 1813	
	2.4	Axle loading fork advanced, laden front/rear	kg	883 / 4755	891 / 4758	979 / 4845	1009 / 4861	
	2.5	Axle loading fork retracted, laden front/rear	kg	2172 / 3466	2180 / 3469	2104 / 3720	2134 / 3736	
DIMENSIONS	4.19	Overall length	l1 (mm)	2523				
	4.20	Length to face of forks	l2 (mm)	1373	1388			
	4.28	Reach distance	l4 (mm)	491				
	4.34.1	Aisle width for pallets 1000mm x 1200mm crossways	Ast (mm)	2834	2845			
	4.34.2	Aisle width for pallets 800mm x 1200mm lengthways	Ast (mm)	2896	2909			
4.35	Turning radius	Wa (mm)	1718					
ELECTRIC-ENGINE	6.3	Battery according to DIN 43531/35/36 A, B, C, no		C	C "Super"	C	C "Super"	
	6.4	Battery voltage/nominal capacity K5	(V) / (Ah)	48 / 560	48 / 620	48 / 700	48 / 775	
	6.5	Battery weight	kg	939	950	1119	1165	

## MR14, MR16, MR16HD - MAST DETAILS, 3 STAGE FULL FREE LIFT (1,400KG / 1,600KG)

	Lift (h3) mm	Free lift (h2) mm	Height of mast lowered (h1) mm	Height of mast extended (h4) mm <sup>(1)</sup>	Weight kg <sup>(2)</sup>
MR14, MR16	5500	1820	2367	6063	961
	6000	1992	2539	6563	1010
	6500	2164	2711	7063	1060
	7500	2508	3055	8063	1164
	7750	2594	3141	8313	1220
	8000	2680	3227	8563	1244
	8500	2852	3399	9063	1299
	9500	3196	3753	10063	1407
	10500	3540	4087	11063	1509
MR16HD	10400	3540	4097	10963	1706
	10900	3712	4269	11463	1763
	11400	3884	4441	11963	1819

<sup>(1)</sup> With load backrest h4 + 508mm.

<sup>(2)</sup> All weights are: mast structures (weldmen t, cylinders, chain, pulley) + carriage + load backrest + oil. **Excluded:** forks, accessories.

## STANDARD EQUIPMENT AND OPTIONS

		MR14 / 16	MR16HD
OPERATOR COMPARTMENT	Feature		
	Intermediate step		■
	Grab handle on overhead guard post		■
	Grab handle under armrest		■
	TouchPoint™ mini-levers mounted on adjustable length armrest		■
	Full suspension seat - 60mm suspension travel cloth upholstery		■
	Full suspension vinyl heated seat		●
	Seat belt		●
	Standard display		■
	Premium display with touch screen		●
	Keyless access		●
	Adjustable steering column		■
	Automatic park brake Yalestop		■
	180° steering		■
360° steering		●	
TRAVEL PERFORMANCE	Travel speed 11km/h		■
	Height of mast, lowered		■
	Speed slow down mast reached forward		■
	Speed slow down on cornering		■
	Speed slow down over free lift		■
LIFT PERFORMANCE / DRIVER ASSIST	3 stage mast / tilting carriage		■
	Simultaneous lift / reach functionality		■
	Mast cushioning over free lift/main lift sections - fixed sensor mounting		■
	Lift Comfort package <sup>(1)</sup>		●
	Height preselector (with / without pallet detection device)		●
	Weight indicator		●
	Carriage mounted camera		●
	Laser line fork positioning aid (above free lift)		●
APPLICATION ENVIRONMENT	Telescopic Forks		●
	High temperature environment		●
	Full view overhead guard		●
	Wet grip tyres		●
	Front and/or rear blue pedestrian awareness spotlights		●
	Red line (side) pedestrian awareness lights		●
	Flashing beacon		●
	Top / front load wheel protection		●
	Side battery change - battery tray rollers		●
	Side battery change table		●
	Audible alarm		●
CHASSIS / BATTERY	Load backrest (1000 mm)		●
	Chassis width (max)	1265 mm	■
	Battery sizes <sup>(2)</sup>	420 - 465 Ah	●
		560 - 620 Ah	●
	700 - 775 Ah	●	

<sup>(1)</sup> Includes; End of stroke slow down on lift. Soft stop on lowering. Height controlled mast cushioning over Free Lift/Main lift mast section. Height indicator.

<sup>(2)</sup> DIN C battery on MR14 / MR16 / MR16HD

■ Standard

● Optional

## VDI 2198 GENERAL SPECIFICATIONS - MR14, MR16

DISTINGUISHING MARK			Yale			
			MR14	MR16	MR16HD	
1.1	Manufacturer		Yale			
1.2	Manufacturer's type designation		MR14	MR16	MR16HD	
1.3	Drive: electric (battery or mains), diesel, petrol, fuel gas		Electric (Battery)		Electric	
1.4	Operator type: hand, pedestrian, standing, seated, order-picker		Seated			
1.5	Rated capacity/Rated load	Q (kg)	1400	1600		
1.6	Load centre distance	(mm)	600			
1.8	Load distance, centre of drive axle to fork <sup>(9)(10)</sup>	x (mm)	258	308	293	
1.9	Wheelbase	y (mm)	1400			
WEIGHTS	2.1	Service weight	3495	3546	4224	
	2.3	Axle loading, unladen front/rear <sup>(5)</sup>	2055 / 1440	2103 / 1443	2428/1796	
	2.4	Axle loading fork advanced, laden front/rear	885 / 4010	810 / 4336	979/4845	
	2.5	Axle loading fork retracted, laden front/rear	1711 / 3184	1779 / 3367	2104/3720	
TYRES/CHASSIS	3.1	Tyres: polyurethane, tophane, NDIIthane, front/rear		NDIIthane / NDIIthane		
	3.2	Tyre size, front	ø mm x mm		343 x 140	
	3.3	Tyre size, rear	ø mm x mm		285 x 100	
	3.5	Wheels, number front/rear (x = driven wheels)		1 x / 2		
	3.7	Tread, rear	b11 (mm)	1155		
DIMENSIONS	4.1	Tilt of mast/fork carriage forward/backward	α / β (o)		2 / 4	
	4.2	Height of mast, lowered	h1 (mm)		2195	
	4.3	Free lift	h2 (mm)		1648	
	4.4	Lift	h3 (mm)		5000	
	4.5	Height, mast extended <sup>(1)</sup>	h4 (mm)		5563	
	4.7	Height of overhead guard (cabin) <sup>(2)</sup>	h6 (mm)		2175	
	4.8	Seat height relating to SIP	h7 (mm)		1082	
	4.10	Height of wheel arms	h8 (mm)		308	
	4.19	Overall length	l1 (mm)		2523	
	4.20	Length to face of forks	l2 (mm)		1373	
	4.21	Overall width <sup>(3)</sup>	b1/b2 (mm)		1265	
	4.22	Fork dimensions DIN ISO 2331	s/e/l (mm)		40 / 80 / 1150	
	4.23	Fork carriage ISO 2328, class/type A, B	40 / 120 / 1150		35/100/1070	
	4.24	Fork-carriage width	b3 (mm)		2A	
	4.25	Distance between fork-arms min/max <sup>(8)</sup>	b5 (mm)		700	
	4.26	Distance between wheel arms/loading surfaces	220 / 640	260 / 680		
	4.28	Reach distance	b4 (mm)		900	
	4.31	Ground clearance, laden, below mast	l4 (mm)		441	
	4.32	Ground clearance, centre of wheelbase	m1 (mm)		75	
	4.34.1	Aisle width for pallets 1000mm x 1200mm crossways <sup>(11)</sup>	m2 (mm)		75	
	4.34.2	Aisle width for pallets 800mm x 1200mm lengthwise <sup>(11)</sup>	Ast (mm)		2828	
	4.35	Turning radius	Wa (mm)		1671	
	4.37	Length across wheel arms	l7 (mm)		1795	
	4.42	Step height (from ground to running board)	mm		550	
	4.43	Step height (between intermediate steps between running board and floor)	mm		371	
	PERFORMANCE DATA	5.1	Travel speed, laden/unladen <sup>(7)</sup>	km/h		11 / 11 (14 / 14)
5.1.1		Travel speed, laden/unladen, backwards <sup>(7)</sup>	km/h		11 / 11 (14 / 14)	
5.2		Lift speed, laden/unladen <sup>(7)</sup>	m/s		0,37 / 0,63 (0,47 / 0,73)	
5.3		Lowering speed, laden/unladen	m/s		0,32 / 0,63 (0,42 / 0,73)	
5.4		Reaching speed, laden/unladen	m/s		0,37/0,63 (0,42/0,73)	
5.7		Gradeability, laden/unladen	%		0,55	
5.8		Max. gradeability laden/unladen	%		10 / 15	
5.9		Acceleration time laden/unladen <sup>(7)</sup>	s		12 / 18	
5.10		Service brake	s		10 / 15	
5.10		Service brake	s		3,3 / 3,3 (2,6 / 2,6)	
ELECTRIC-ENGINE	6.1	Drive motor S2 60 minute rating	kW		3,4 / 3,4 (2,7 / 2,7)	
	6.2	Lift motor, S3 15% rating	kW		5.4	
	6.3	Battery according to DIN 43531 / 35 / 36 A,B,C, no	kW		9.9	
	6.4	Battery voltage/nominal capacity K5	(V) / (Ah)		C	
	6.5	Battery weight <sup>(4)</sup>	kg		48 / 700 (6)	
	6.6	Energy consumption according to VDI cycle	kWh/h @ Nr of Cycles		48 / 700	
ADD. INFO.	8.1	Type of drive unit	AC-Controller		AC	
	10.1	Operating pressure for attachments	bar		180	
	10.2	Oil volume for attachment	l/min		20	
	10.7	Sound pressure level at the driver's seat	dB (A)		<69.7	

<sup>(1)</sup> With load backrest h4 + 508 mm MR14 / MR16 / MR16HD <sup>(3)</sup> With load wheels lateral covers <sup>(5)</sup> Forks retracted <sup>(7)</sup> Values in brackets are optional  
<sup>(2)</sup> With beacon h6 + 120mm <sup>(4)</sup> These values may vary of +/- 5% <sup>(6)</sup> See Batteries table <sup>(8)</sup> Side shift stroke is +/-75mm on all trucks

All values are nominal values and they are subject to tolerances. For further information, please contact the manufacturer. Yale products might be subject to change without notice. Lift trucks illustrated may feature optional equipment. Values may vary with alternative configurations.



# About Yale



Yale Lift Truck Technologies leverages over a century of material handling experience and substantial investment in innovation to bring the most advanced technology-driven lift truck solutions to market. The company offers a full line of award-winning lift trucks, including reach trucks, order pickers, turret trucks, pallet jacks and trucks, pallet stackers, tow tractors and counterbalanced forklifts, as well as powerful operator assist solutions, proven robotics and a wide range of power sources to help customers adapt to today's demanding supply chain. Yale and its independent dealer network support these solutions with comprehensive after-sales service, parts, financing and training.

Yale Lift Truck Technologies is a trading name of Hyster-Yale Asia-Pacific Pty Ltd., a wholly owned subsidiary of Hyster-Yale Materials Handling, Inc. (NYSE:HY) which is headquartered in Cleveland, Ohio and operates globally.

## MATERIALS HANDLING FOR:

3PL

Auto Parts Distribution

Beverage

Cold & Frozen Foods

Food Distribution

Food Processing

Furniture & Furnishings

Government

Health & Pharma

Home Centers

Retail & E-commerce

Yale Pacific

1/23 Rowood Road, Prospect NSW 2148

Tel: +61 (2) 9795 3800 | Fax: +61 (2) 9792 8484

Yale Asia

16 Tuas Avenue 20, Singapore 638827

Tel: +65 6863 3387 | Fax: +65 6863 3349

**yale.com**

© 2023 Hyster-Yale Group, Inc., all rights reserved. YALE and  are trademarks of Hyster-Yale Group, Inc. Trucks may be shown with optional equipment and/or features not available in all regions. Specifications and details in this brochure are subject to change without prior notification.