



**STRONG PARTNERS.
TOUGH TRUCKS.™**



HYSTER UT SERIES

3-WHEEL ELECTRIC FORKLIFT

J1.6-2.0UTT / 1600-2000KG

HYSTER.COM.AU

FEATURES

1 HIGH STRENGTH OVERHEAD GUARD

The profiled steel overhead guard features high strength materials to enhance reliability and operator protection.

2 AC CONTROLLER

European designed controllers optimise battery power consumption. AC traction and hydraulic motors improve precision. All are easily accessible to minimise service time.

3 WIDE AND LOW STEP

The conveniently positioned non-slip step coupled with large grab handles provide easy and secure access to the truck.



4 WIDE VIEW MAST

The wide view mast delivers excellent visibility of the load and operator's forward field of view. Thus optimising comfort and productivity.

5 SMALL, ADJUSTABLE STEERING WHEEL

The small diameter steering wheel requires low effort, promoting light and precise operation. The adjustable steer column optimises comfort and convenience.

6 DUAL DRIVE MOTORS

The compact structure of the drive system provides adequate access for maintenance. Precision cut gears are incorporated, leading to reduced wear and lower noise levels.

OVERVIEW

THE HYSTER® UT SERIES PROVIDES THE IDEAL SOLUTION TO MEET YOUR LESS FREQUENT USAGE NEEDS, WITHOUT COMPROMISING ON PERFORMANCE.

The Range

The J1.6-2.0UTT range is available in three different capacities:

1,600KG – J1.6UTT

1,800KG – J1.8UTT

2,000KG – J2.0UTT

Design

The design of the UT range has been engineered with the driver in mind. The ergonomically designed operator compartment, with a familiar layout, means that drivers will be able to work effortlessly. A range of standard features and options allow the truck to be configured to the needs of the application.

Low Cost of Ownership

The use of high quality and robust components within the UT series deliver a reliable operation with limited wear and tear. Maintenance costs and requirements are further reduced by simple, readily available, genuine and cost effective replacement parts.

Hydraulics

High quality cylinders with hard chrome rods reduce seal wear for long life. A full-flow, low pressure filter on the return line keeps the hydraulic oil clean, which helps to minimise seal and pump wear. In addition, this keeps the control valve in good condition, leading to low service costs.

ENGINEERED FOR DRIVERS



Safety and Compliance

- High visibility, shock absorbing mast as standard enables soft landing
- Controllable mast lowering speed to avoid damage
- Secure overhead guard, passed CE drop test
- LED lights as standard
- Operator presence system

Performance

- On-demand hydraulic power steering, with twin drive motor system, delivers superb manoeuvrability and low energy consumption
- Excellent stopping capability - delivered through maintenance free oil immersed brakes and regenerative braking system
- Simple and clear dash display helps the operator to be fully informed
- Display with integrated performance selection functions
- AC traction and lifting motors, with electronic control, improves performance
- Sequential seatbelt interlock available to comply with Australia ISO standards

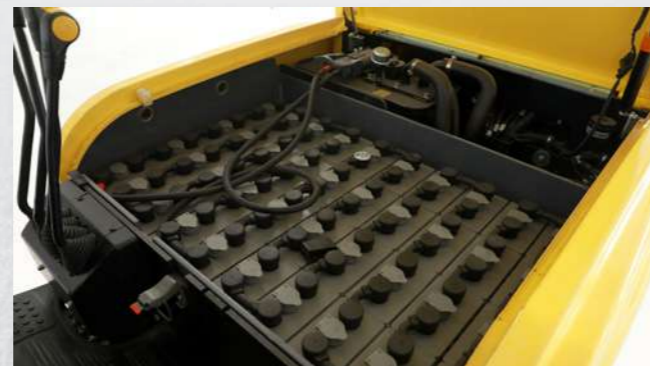

Comfort

- Hydraulic power steering requires low steering effort for precise positioning
- Driver fatigue minimised by full suspension, superior comfort and lumbar support seat
- Adjustable steering column and seat to suit all operators
- Low noise and vibration
- Low entrance step, large uncluttered floor space and ergonomically positioned pedals
- Ergonomic handbrake and operator controls – maximising comfort

Service

- AC traction and hydraulic motors reduce maintenance costs
- Easy service access to the controllers – mounted inside the counterweight, at waist height, protected by removable cover
- IP54 Design – protects the hydraulic and drive motor components
- Readily accessible drivetrain - minimising service time
- CANbus communication simplifies troubleshooting

J1.6UTT MAST AND CAPACITY TABLE

Mast Type	Max fork height (mm)	Overall Extended Height			Free lift		Mast Tilt		Capacity without side shift	
		Lowered height (mm)	Lift height		Without LBR (mm)	With LBR (mm)	Forward (Deg)	Back (Deg)	@ 500mm	@ 600mm
			Without LBR (mm)	With LBR (mm)					Single Pneumatic Tyre (kg)	Single Pneumatic Tyre (kg)
		1.6T	1.6T	1.6T					1.6T	1.6T
2LFL	3000	1975	3490	4010	35	35	6	6	1600	1435
	3300	2125	3790	4310	35	35	6	6	1600	1435
	3500	2225	3990	4510	35	35	6	6	1600	1435
	3700	2325	4190	4710	35	35	6	6	1600	1435
	4000	2525	4490	5010	35	35	3	5	1600	1435
	4500	2775	4990	5510	35	35	3	5	1400	1255
	5000	3025	5490	6010	35	35	3	5	1250	1120
2FFL	5500	3325	5990	6510	35	35	3	5	1150	1030
	6000	3575	6490	7010	35	35	3	5	1050	940
	3000	1975	3490	4010	1510	990	6	6	1600	1435
	3300	2125	3790	4310	1660	1140	6	6	1600	1435
	3500	2225	3990	4510	1760	1240	6	6	1600	1435
	3700	2325	4190	4710	1860	1340	6	6	1600	1435
	4000	2525	4490	5010	2060	1540	3	5	1600	1435
3FFL	4350	1975	4840	5360	1510	990	3	5	1500	1345
	4500	2025	4990	5510	1560	1040	3	5	1400	1255
	4800	2125	5290	5810	1660	1140	3	5	1300	1165
	5000	2225	5490	6010	1760	1240	3	5	1250	1120
	5500	2390	5990	6510	1925	1405	3	5	1150	1030
	6000	2575	6490	7010	2110	1590	3	5	1050	940
	6500	2790	6990	7510	2325	1805	3	5	900	805

J1.8UTT MAST AND CAPACITY TABLE

Mast Type	Max fork height (mm)	Overall Extended Height			Free lift		Mast Tilt		Capacity without side shift	
		Lowered height (mm)	Lift height		Without LBR (mm)	With LBR (mm)	Forward (Deg)	Back (Deg)	@ 500mm	@ 600mm
			Without LBR (mm)	With LBR (mm)					Single Pneumatic Tyre (kg)	Single Pneumatic Tyre (kg)
		1.8T	1.8T	1.8T					1.8T	1.8T
2LFL	3000	1975	3490	4010	35	35	6	6	1800	1615
	3300	2125	3790	4310	35	35	6	6	1800	1615
	3500	2225	3990	4510	35	35	6	6	1800	1615
	3700	2325	4190	4710	35	35	6	6	1800	1615
	4000	2525	4490	5010	35	35	3	5	1800	1615
	4500	2775	4990	5510	35	35	3	5	1600	1435
	5000	3025	5490	6010	35	35	3	5	1450	1300
2FFL	5500	3325	5990	6510	35	35	3	5	1200	1075
	6000	3575	6490	7010	35	35	3	5	1100	985
	3000	1975	3490	4010	1510	990	6	6	1800	1615
	3300	2125	3790	4310	1660	1140	6	6	1800	1615
	3500	2225	3990	4510	1760	1240	6	6	1800	1615
	3700	2325	4190	4710	1860	1340	6	6	1800	1615
	4000	2525	4490	5010	2060	1540	3	5	1800	1615
3FFL	4350	1850	4490	5010	1385	865	3	5	1800	1615
	4500	1975	4840	5360	1510	990	3	5	1700	1525
	4800	2025	4990	5510	1560	1040	3	5	1600	1435
	5000	2125	5290	5810	1660	1140	3	5	1500	1345
	5500	2225	5490	6010	1760	1240	3	5	1450	1300
	6000	2390	5990	6510	1925	1405	3	5	1200	1075
	6500	2575	6490	7010	2110	1590	3	5	1100	985

J2.0UTT MAST AND CAPACITY TABLE

Mast Type	Max fork height (mm)	Overall Extended Height			Free lift		Mast Tilt		Capacity without side shift	
		Lowered height (mm)	Lift height		Without LBR (mm)	With LBR (mm)	Forward (Deg)	Back (Deg)	@ 500mm	@ 600mm
			Without LBR (mm)	With LBR (mm)					Single Pneumatic Tyre (kg)	Single Pneumatic Tyre (kg)
		2.0T	2.0T	2.0T					2.0T	2.0T
2LFL	3000	1975	3490	4010	54	54	6	6	2000	1795
	3300	2125	3790	4310	54	54	6	6	2000	1795
	3500	2225	3990	4510	54	54	6	6	2000	1795
	3700	2325	4190	4710	54	54	6	6	2000	1795
	4000	2525	4490	5010	54	54	3	5	2000	1795
	4500	2775	4990	5510	54	54	3	5	1800	1615
	5000	3025	5490	6010	54	54	3	5	1500	1345
2FFL	5500	3325	5990	6510	54	54	3	5	1300	1165
	6000	3575	6490	7010	54	54	3	5	1200	1075
	3000	1975	3490	4010	1510	990	6	6	2000	1795
	3300	2125	3790	4310	1660	1140	6	6	2000	1795
	3500	2225	3990	4510	1760	1240	6	6	2000	1795
	3700	2325	4190	4710	1860	1340	6	6	2000	1795
	4000	2525	4490	5010	2060	1540	3	5	2000	1795
3FFL	4350	1850	4490	5010	1385	865	3	5	2000	1795
	4500	1975	4840	5360	1510	990	3	5	1900	1705
	4800	2025	4990	5510	1560	1040	3	5	1800	1615
	5000	2125	5290	5810	1660	1140	3	5	1650	1480
	5500	2225	5490	6010	1760	1240	3	5	1500	1345
	6000	2390	5990	6510	1925	1405	3	5	1300	1165
	6500	2575	6490	7010	2110	1590	3	5	1200	1075

Note: For integral sideshift deduct 50kg from stated capacity

	1.1	Manufacturer	Measurement	Hyster	Hyster	Hyster
Distinguishing mark	1.2	Model designation		J1.6UTT	J1.8UTT	J2.0UTT
	1.3	Power: battery, diesel, LPG, electric mains		Battery	Battery	Battery
	1.4	Operation: manual, pedestrian, stand, seat, orderpicker		Seated	Seated	Seated
	1.5	Load capacity	Q (kg)	1600	1800	2000
	1.6	Load centre	c (mm)	500	500	500
	1.8	Load distance	x (mm)	371	371	371
Weight	2.1	Unladen weight (max. battery)	kg	3120	3190	3380
	2.2	Axle loading, laden front / rear (max. battery)	kg	4010 / 660	4420 / 510	4870 / 580
	2.3	Axle loading, unladen front / rear (max. battery)	kg	1480 / 1640	1500 / 1690	1580 / 1810
Tyres, chassis	3.1	Tyres: L=pneumatic, V=cushion, SE= superelastic		SE	SE	SE
	3.2	Tyre size, front		18 x 7-8	18 x 7-8	200 / 50-10
	3.3	Tyre size, rear		15 x 4.5-8	15 x 4.5-8	15 x 4.5-8
	3.5	Number of wheels, front / rear (X = driven)		2x / 2	2x / 2	2x / 2
	3.6	Track width, front	b10 (mm)	933	933	952
Dimensions	4.1	Mast tilt, forward α / back β	degrees	6/6	6/6	6/6
	4.2	Height of mast, lowered	h1 (mm)	1992	1992	1990
	4.4	Lift height *	h3 (mm)	3036	3036	3045
	4.5	Height of mast, extended E	h4 (mm)	4030	4030	4000
	4.7	Height to top of overhead guard m	h6 (mm)	2002	2002	2004
	4.8	Seat height u	h7 (mm)	965	965	965
	4.12	Towing coupling height	h10 (mm)	445	445	485
	4.19	Overall length (with forks)	l1 (mm)	2894	2894	3153
	4.20	Length to face of forks	l2 (mm)	1974	1974	2084
	4.21	Overall width	b1 (mm)	1084	1084	1140
	4.22	Fork dimensions	s/e/l (mm)	35 / 100 / 920	35 / 100 / 920	40 / 120 / 1070
	4.23	Fork carriage DIN 15173. Class, A / B		2A	2A	2A
	4.24	Fork carriage width E	b3 (mm)	950	950	950
	4.25	Width over forks	b5 (mm)	890	890	890
	4.31	Ground clearance, laden, below mast	m1 (mm)	90	90	90
	4.32	Ground clearance at centre of wheelbase	m2 (mm)	96	96	96
	4.33	Aisle width with pallets 1000 mm long x 1200 mm wide	Ast (mm)	3290	3290	3445
	4.34	Aisle width with pallets 800 mm wide x 1200 mm long	Ast (mm)	3415	3415	3410
4.35	Outer turning radius	Wa (mm)	1601	1601	1716	
4.36	Inner turning radius	b13 (mm)	0	0	0	
Performance data	5.1	Travel speed laden / unladen	km/h	14 / 16	14 / 16	14 / 16
	5.2	Lifting speed laden / unladen	mm/s	352 / 500	349 / 500	310 / 500
	5.3	Lowering speed laden / unladen	mm/s	344 / 420	382 / 421	390 / 430
	5.6	Maximum drawbar pull laden / unladen, 5 minute rating	N	15500 / 10000	15000 / 10500	15500 / 12000
	5.8	Maximum gradeability with / without load, 5 minute rating	%	20 / 30	20 / 30	20 / 30
	5.9	Acceleration time with / without load 10m	sec	4.4 / 4.3	4.4 / 4.3	5.9 / 5.6
Electric-Motor	6.1	Drive Motor Rating, S2, 60min	kW	2 x 5.0	2 x 5.0	2 x 5.0
	6.2	Lifting motor, S3 15% rating	kW	11	11	11
	6.3	Battery DIN 43531 / 35 / 36 A, B, C, no		43531A	43531A	43531A
	6.4	Battery voltage / capacity (5hr rate)	V/Ah	48 / 460	48 / 460	48 / 600
	6.5	Battery weight (min/max)	kg	945	945	1090
	6.6	Battery dimensions	l/w/h (mm)	830 / 630 / 627	830 / 630 / 627	830 / 738 / 627
Additional data	8.1	Drive control		AC	AC	AC
	8.2	Manufacturer		ZAPI	ZAPI	ZAPI
	8.3	Operating pressure for attachments x	bar	145	175	175
	8.4	Oil volume for attachments	Vmin	38	38	38
	8.5	Average noise level at operator's ear ~	dB (A)	64.8	64.8	69.6
8.5	Towing coupling, type DIN		Ø32	Ø32	Ø32	

→ LPAZ, measured according to the test cycles and based on the weighting values contained in EN12053
 ~ Bottom of forks
 u Full suspension specified
 E Without load backrest
 m h6 subject to +/- 5 mm tolerance
 x Variable

Specification data is based on VDI 2198, with the following configuration: Complete truck with 3000mm 2-stage limited free lift mast, standard carriage and forks, overhead guard and standard superelastic drive and steer tyres.

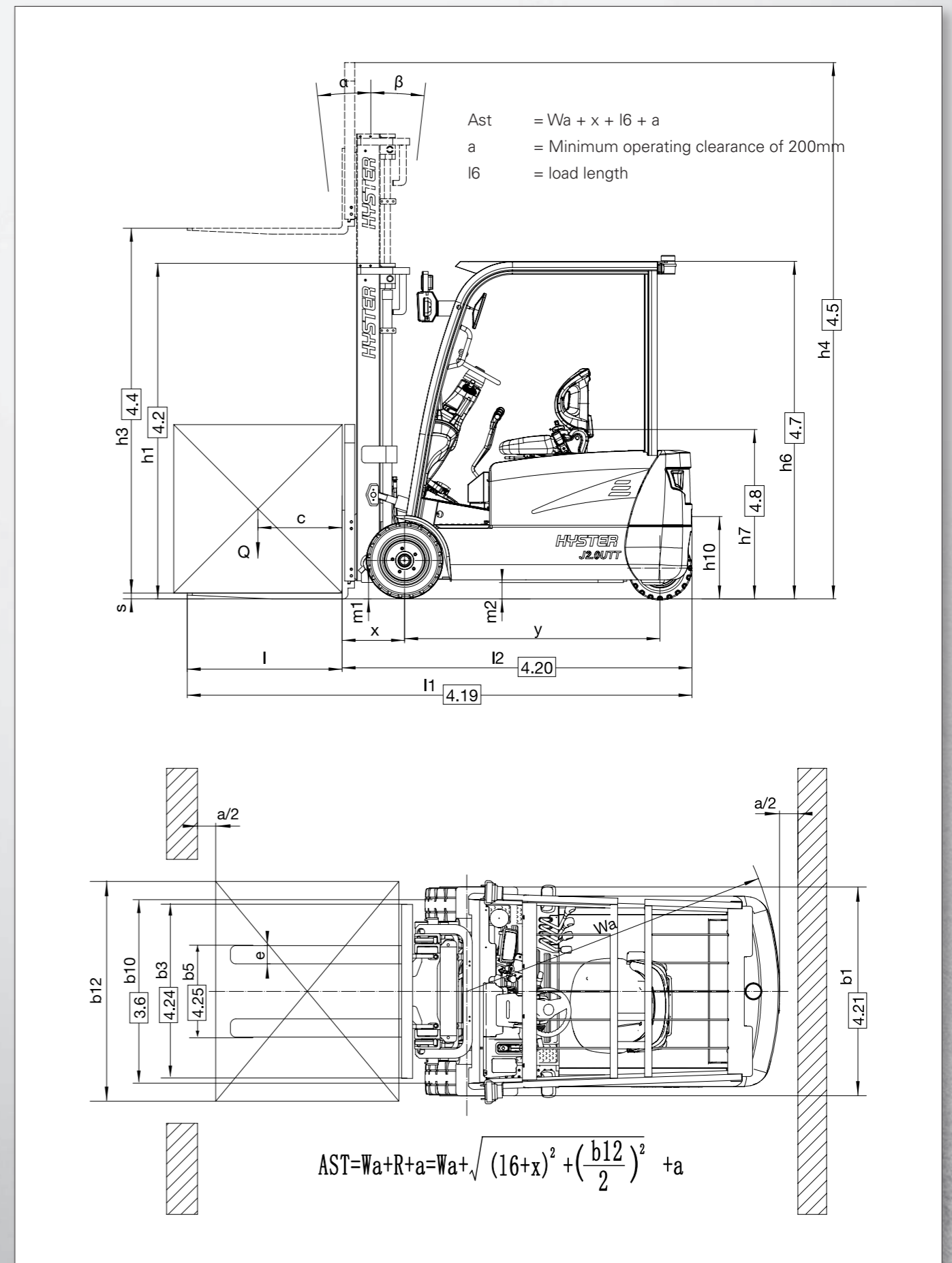



HYSTER® DEALERS

Contact your nearest Hyster® Dealership
by visiting www.hyster.com.au



HYSTER PACIFIC

1 Bullecourt Avenue, Milperra NSW, Australia 2214
Tel: +61 (2) 9795 3800 Fax: +61 (2) 9792 8484
hyster.com/pacific/en-au

HYSTER ASIA

16 Tuas Avenue 20, Singapore 638827
Tel: +65 6863 3387 Fax: +65 6863 3349
hyster.com/asia/en-sg



/Hysterasiapacific



HysterJAPIC



Hyster Asia-Pacific