



WWW.HYSTER.COM

**INTERNAL COMBUSTION  
COUNTERBALANCED FORKLIFT**  
**PRODUCT BROCHURE**

# H4.0-5.0UT

---



# FEATURES

## 1 HIGH STRENGTH OHG

Overhead guard featuring high strength profiled steel sections to enhance operator protection.

## 2 FULL SUSPENSION SEAT

Full suspension seat that offers excellent comfort, fitted with an operator's presence system as standard.

## 3 LOW STEP HEIGHT

Convenient step placing to suit a variety of driver heights to ensure easy access to the truck at all times.

## 4 WIDE VIEW MAST

The wide view mast delivers excellent visibility of the load and operator's forward field of view, optimising ergonomics and truck productivity.

## 5 SMALL STEERING WHEEL

The adjustable steering wheel is convenient for the operator, providing 8 degrees of tilt adjustment. Allowing for good manoeuvrability when working in confined spaces.

## 6 INDUSTRIAL ENGINE

The UT Mitsubishi Industrial engine provides good reliability and easy sourcing of replacement parts.





# OVERVIEW

---

The Hyster® UT Series provides the ideal solution to meet your less frequent usage needs, without compromising on performance.

## The range

The range consists of 4,000-5,000kg. IC counterbalance, pneumatic tyre forklift trucks, available in three different capacities (lift and load centre):

**4,000KG - H4.0UT**

**4,500KG - H4.5UT**

**5,000KG - H5.0UT**

Each model is available with diesel, LPG, dual fuel, 2 speed forward /1 reverse powershift transmission and a range of front end equipment options to suit varying application requirements.

## Easy to operate

The ergonomically designed operator compartment, with a familiar automotive layout, means that drivers will be able to work comfortably.

A range of standard features and options help to ensure that the truck is configured to the needs of the application.

## Serviceability

Due to the simplicity of the components and specifications, servicing can be carried out quickly and easily.

## Low cost of ownership

The use of high quality, robust components, efficient filtration and excellent cooling helps contribute to reliable operations and lower wear and tear. This, together with the fast availability of cost-effective replacement parts reduces service maintenance requirements and costs.

## Ergonomics

- Hyster UT 3.5" LCD
- Spacious foot room
- Dual suspension system (transmission and operator)
- Hand parking brake lever with button significantly reduces fatigue in operation
- Small diameter steering wheel with adjustable tilt steering column

## Safety and stability

- Wide view mast
- High strength overhead guard
- Muffler and engine protective system
- Low centre of gravity

## Easy maintenance

- Large access area for service and repairs
- Simple components
- Computer-based diagnostics not required

## Reliability and exchangeability

- One piece welded overhead guard
- Exchangeable components across models

## Environmental protection

- Noise isolation material
- Environmentally-aware design

# FEATURES

## ENGINEERED FOR DRIVERS WITH COMFORT, SAFETY AND ERGONOMICS



### Hyster display with 3.5" LCD

- The Hyster UT Series Forklift adopts a 3.5" LCD display, providing convenient viewing of the display data when driving and operating



### Hand parking brake

- Low effort to operate park brake lever
- Hand parking brake lever with button reduces operator fatigue



### Spacious footwell

- Spacious foot room design provides comfort, convenience and safety
- Control pedals provide extra foot space which reduces operator fatigue and increases operator comfort

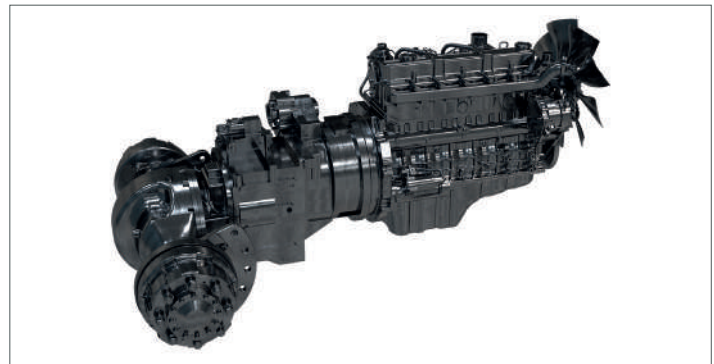

### Transmission and drive axle

- Heavy duty and robust Powershift transmission with two forward gears and one reverse
- Durable and long life Drive Axle

# FEATURES



## Small diameter steering wheel with adjustable steer column

- The 300mm diameter steering wheel is easy to manipulate, responsive, with optimum maneuverability when working confined spaces
- The ideally positioned steering wheel allows 8 degrees of tilt adjustment, to suit a variety of different operators



## High-strength overhead guard

- Profiled steel overhead guard
- High strength roof enhances reliability and operator protection

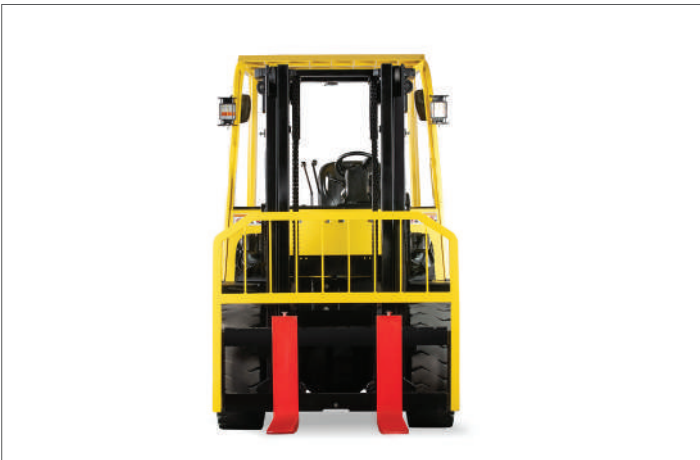

## Good through-mast visibility

- The wide view mast delivers excellent visibility of the load and operator's forward field of view. Thus optimising comfort, safety and productivity
- Mast composite roller structure



## Large access area for service and repairs

- Large access space to engine compartment makes service and repairs easy

# SERVICING



## Suspension seat

- Full suspension seat offers excellent comfort
- Operator presence system as standard



## Exchangeable components

- Engine cover, instrument panel, display and most other components are exchangeable with other capacities in the same range
- Front fenders adaptable to single or dual wheel configuration

## Improved lift speed

- Enabling high productivity

## OPTIONS

HYSTER® UT Series trucks feature a comprehensive range of standard equipment, with options to suit the specific needs of your application, including:

- 4th Function Hydraulics (+clamping function)
- Pneumatic-shaped solid (tyres)
- Various fork lengths
- Integral sideshift
- Rear, LED work light
- Strobe light
- Backup alarm
- High air intake with pre-cleaner
- Tilt cylinder boots
- Various mast heights
- Polycarbonate top screen
- Front window with wiper
- Alternate tilt angles (mast)

*Please refer to the Price List for full option configurations.*



# TRUCK DIMENSIONS

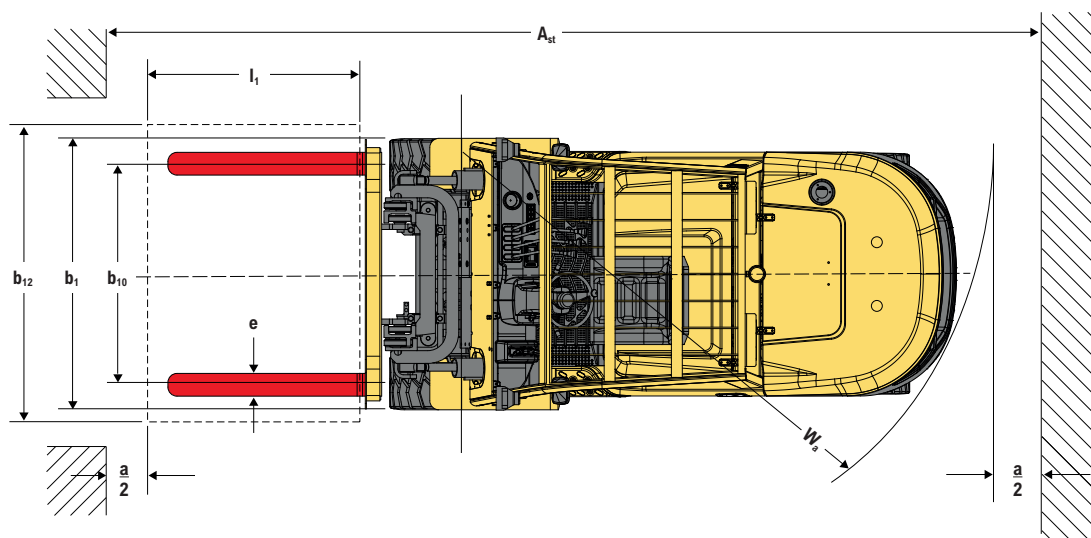
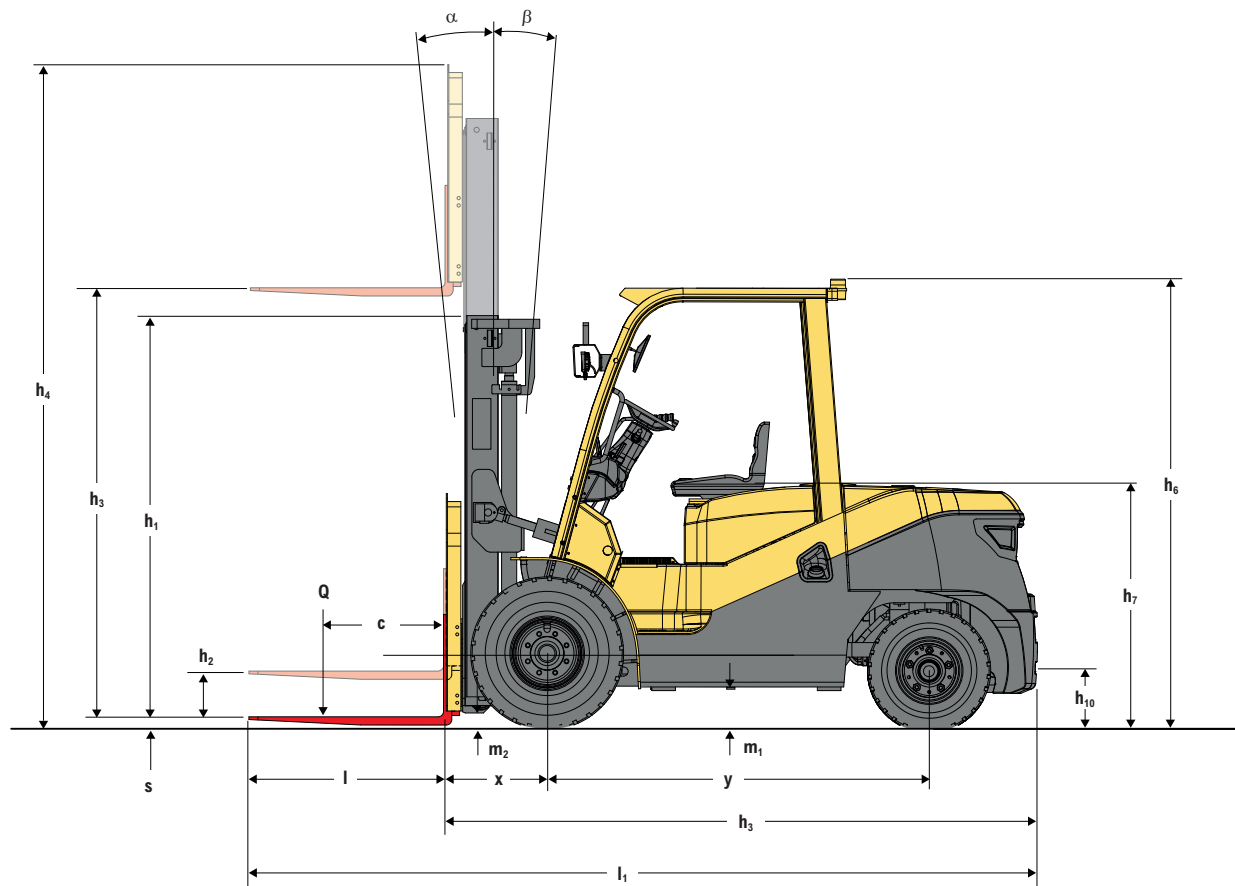

# H4.OUT SPECIFICATIONS

DISTINGUISHING MARK	1.1	Manufacturer	Hyster					
	1.2	Model designation	H4.OUT					
	1.3	Drive: electric (battery or mains), diesel, petrol, fuel gas	Diesel	Diesel Stage V	Dual fuel	LPG		
	1.4	Operator type: hand, pedestrian, standing, seated, order-picker	Seat					
WEIGHT	1.5	Rated capacity/rated load	(kg)	4000				
	1.6	Load centre distance	(mm)	500				
	1.8	Load distance, centre of drive axle to fork	(mm)	575				
TYRES, CHASSIS	1.9	Wheelbase (with mast vertical)	(mm)	2100				
	2.1	Service weight	kg	6435				
	2.2	Axle loading, laden front/rear	kg	9195/1240				
	2.3	Axle loading, unladen front/rear	kg	3075/3360				
	3.1	Tyres: Solid rubber, superelastic, pneumatic, polyurethane		pneumatic				
	3.2	Tyre size, front		300-15-18PR				
	3.3	Tyre size, rear		7.00-12-12PR				
	3.5	wheels, number front/rear		2X2				
	3.6	Tread, front	(mm)	1190				
	3.7	Tread, rear	(mm)	1130				
DIMENSIONS	4.1	Tilt of mast/fork carriage, forward /backward	$\alpha / \beta$ (°)	6/12				
	4.2	Height, mast lowered	(mm)	2250				
	4.3	Free lift	(mm)	150				
	4.4	Lift	(mm)	3000				
	4.5	Height, mast extended	(mm)	4260				
	4.7	Height of overhead guard(cabin)	(mm)	2250 (2400)				
	4.8	Seat height/stand height	(mm)	1350				
	4.12	Towing coupling height	(mm)	340				
	4.19	Overall length	(mm)	4280				
	4.20	Length to face of forks	(mm)	3210				
	4.21	Overall width, std/dual	(mm)	1490/1924				
	4.22	Fork dimensions ISO2331	(mm)	50/150/1070				
	4.23	Fork carriage ISO 2328. Class/type, A/B		ISO 3A				
	4.24	Fork carriage width	(mm)	1380				
	4.31	Ground clearance, laden, below mast	(mm)	155/130				
	4.32	Ground clearance, centre of wheelbase	(mm)	186				
	4.33	Load dimension b 12*/6 crossways		1000x1000				
	4.34	Aisle width with predetermined load dimensions	(mm)	4695				
	4.34.1	Aisle width with pallets 1000 mm x 1200 mm crossways	(mm)	4825				
	4.34.2	Aisle width with pallets 800 mm x 1200 mm crossways	(mm)	4825				
4.35	Turning radius	(mm)	2850					
4.36	Internal turning radius	b13	845					
PERFORMANCE DATA	5.1	Travel speed, laden/unladen	km/h	Shift 2: 24/25 Shift 1: 17/18	Shift 2: 22/24 Shift 1: 15/16	Shift 2: 25/28 Shift 1: 18/19	Shift 2: 26/28 Shift 1: 18/19	
	5.1.1	Travel speed, laden/unladen, backwards	km/h	Shift 1: 19/20	Shift 1: 17/19	Shift 1: 21/22		
	5.2	Lifting speed, laden/unladen	mm/s	530/560				
	5.3	Lowering speed laden/unladen	mm/s	480/500				
	5.6	Max. drawbar pull laden/unladen	N	30000/23000	25000/21000	31500/30000	33000/32000	
	5.7	Gradeability, laden/unladen	%	24/25	20/25	24/25	25/25	
	5.9	Acceleration time, laden/unladen	sec	with load: 5.05(S1)/4.76(S2) without load: 4.15(S1)/3.95(S2)		TBC	with load: 5.07(S1)/4.78(S2) without load: 4.15(S1)/3.95(S2)	
	5.10	Service brake		hydraulic				
	COMBUSTION-ENGINE	7.1	Engine manufacturer/type		Mitsubishi S6S	Kubota V3800-CR-TE5CB-HYM-1	Kubota WG3800-GL-C	Kubota WG3800-L-C
		7.2	Engine power according to DIN ISO 1585	Kw	52	55.4	57.6	63.2
7.3		Rated speed	min-1	2300	2200	2400		
7.4		Number of cylinders/displacement	-/cm3	6/4996		4/3769		
7.5		Fuel consumption according to VDI cycle	l/h or kg/h	7.02 l/h or 5.9 kg/h	TBC	6.15 kg/h	6.24 kg/h	
7.6		Turnover output	t/h	270 t/h	TBC	280 t/h	286 t/h	
7.7		Energy consumption at turnover output	l/h or kg/h	9.26 l/h or 7.77 kg/h	TBC	7.93 kg/h	8.16 kg/h	
7.8		Generator	A	35		100		
7.9		Vehicle electrical system voltage	V	24		12		
7.10		Battery voltage/nominal capacity	V/Ah	2-12/60	12/120		12/90	
ADDITIONAL DATA	8.1	Type of drive unit		E-Hydraulic				
	10.1	Operating pressure for attachments	bar	195				
	10.2	Oil volume for attachments	l/min	70				
	10.4	Fuel tank capacity	L	100				
	10.7	Sound pressure level at the driver's seat	dB (A)	88	81.5	88		
	10.7.1	Sound power level during the workcycle	dB (A)	109.6	99.7	109.6		
	10.8	Towing coupling, type DIN		PIN				

# H4.5UT SPECIFICATIONS

DISTINGUISHING MARK	1.1	Manufacturer	Hyster					
	1.2	Model designation	H4.5UT					
	1.3	Drive: electric (battery or mains), diesel, petrol, fuel gas	Diesel	Diesel Stage V	Dual fuel	LPG		
	1.4	Operator type: hand, pedestrian, standing, seated, order-picker	Seat					
WEIGHT	1.5	Rated capacity/rated load	(kg)	4500				
	1.6	Load centre distance	(mm)	500				
	1.8	Load distance, centre of drive axle to fork	(mm)	575				
TYRES, CHASSIS	1.9	Wheelbase (with mast vertical)	(mm)	2100				
	2.1	Service weight	kg	6670				
	2.2	Axle loading, laden front/rear	kg	9917/1253				
	2.3	Axle loading, unladen front/rear	kg	2910/3760				
	3.1	Tyres: solid rubber, superelastic, pneumatic, polyurethane	pneumatic					
	3.2	Tyre size, front	300-15-18PR					
	3.3	Tyre size, rear	7.00-12-12PR					
	3.5	wheels, number front/rear	2X2					
	3.6	Tread, front	(mm)	1190				
	3.7	Tread, rear	(mm)	1130				
DIMENSIONS	4.1	Tilt of mast/fork carriage, forward /backward	$\alpha / \beta$ (°)	6/12				
	4.2	Height, mast lowered	(mm)	2250				
	4.3	Free lift	(mm)	150				
	4.4	Lift	(mm)	3000				
	4.5	Height, mast extended	(mm)	4260				
	4.7	Height of overhead guard (cabin)	(mm)	2250 (2400)				
	4.8	Seat height/stand height	(mm)	1350				
	4.12	Towing coupling height	(mm)	340				
	4.19	Overall length	(mm)	4280				
	4.20	Length to face of forks	(mm)	3210				
	4.21	Overall width, std/dual	(mm)	1490/1924				
	4.22	Fork dimensions ISO2331	(mm)	50/150/1070				
	4.23	Fork carriage ISO 2328. Class/type, A/B	ISO 3A					
	4.24	Fork carriage width	(mm)	1380				
	4.31	Ground clearance, laden, below mast	(mm)	155/130				
	4.32	Ground clearance, centre of wheelbase	(mm)	186				
	4.33	Load dimension b 12*/6 crossways	1000x1000					
	4.34	Aisle width with predetermined load dimensions	(mm)	4695				
	4.34.1	Aisle width with pallets 1000 mm x 1200 mm crossways	(mm)	4825				
	4.34.2	Aisle width with pallets 800 mm x 1200 mm crossways	(mm)	4825				
4.35	Turning radius	(mm)	2850					
4.36	Internal turning radius	b13	845					
PERFORMANCE DATA	5.1	Travel speed, laden/unladen	km/h	Shift 2: 24/25 Shift 1: 17/18	Shift 2: 22/24 Shift 1: 15/16	Shift 2: 25/28 Shift 1: 18/19	Shift 2: 26/28 Shift 1: 18/19	
	5.1.1	Travel speed, laden/unladen, backwards	km/h	Shift 1: 19/20	Shift 1: 17/19	Shift 1: 21/22		
	5.2	Lifting speed, laden/unladen	mm/s	530/560				
	5.3	Lowering speed laden/unladen	mm/s	480/500				
	5.6	Max. drawbar pull laden/unladen	N	30000/23000	25000/21000	31500/30000	33000/32000	
	5.7	Gradeability, laden/unladen	%	22/25	20/25	23/25		
	5.9	Acceleration time, laden/unladen	sec	with load: 5.21(S1)/4.86(S2) without load: 4.32(S1)/4.15(S2)	TBC	with load: 5.29(S1)/4.93(S2) without load: 4.32(S1)/4.15(S2)		
	5.10	Service brake	hydraulic					
	7.1	Engine manufacturer/type	Mitsubishi S6S		Kubota V3800-CR-TE5CB-HYM-1	Kubota WG3800-GL-C	Kubota WG3800-L-C	
	7.2	Engine power according to DIN ISO 1585	Kw	52	55.4	57.6	63.2	
COMBUSTION-ENGINE	7.3	Rated speed	min-1	2300	2200	2400		
	7.4	Number of cylinders/displacement	-/cm3	6/4996	4/3769			
	7.5	Fuel consumption according to VDI cycle	l/h or kg/h	7.26 l/h or 6.1 kg/h	TBC	6.5 kg/h	6.85 kg/h	
	7.6	Turnover output	t/h	300t/h	TBC	310 t/h	317 t/h	
	7.7	Energy consumption at turnover output	l/h or kg/h	9.62 l/h or 8.07 kg/h	TBC	8.27 kg/h	8.36 kg/h	
	7.8	Generator	A	35	100			
	7.9	Vehicle electrical system voltage	V	24	12			
	7.10	Battery voltage/nominal capacity	V/Ah	2-12/60	12/120	12/90		
	ADDITIONAL DATA	8.1	Type of drive unit	E-Hydraulic				
		10.1	Operating pressure for attachments	bar	195			
10.2		Oil volume for attachments	l/min	70				
10.4		Fuel tank capacity	L	100				
10.7		Sound pressure level at the driver's seat	dB (A)	88	81.5	88		
10.7.1		Sound power level during the workcycle	dB (A)	109.6	99.7	109.6		
10.8	Towing coupling, type DIN	PIN						

# H5.OUT SPECIFICATIONS

		Distinguishing Mark						
DISTINGUISHING MARK	1.1	Manufacturer	Hyster					
	1.2	Model designation	H5.OUT					
	1.3	Drive: electric(battery or mains), diesel, petrol, fuel gas	Diesel	Diesel Stage V	Dual fuel	LPG		
	1.4	Operator type: hand, pedestrian, standing, seated, order-picker	Seat					
	1.5	Rated capacity/rated load	(kg)	5000				
	1.6	Load centre distance	(mm)	500				
	1.8	Load distance, centre of drive axle to fork	(mm)	580				
	1.9	Wheelbase (with mast vertical)	(mm)	2100				
	WEIGHT	2.1	Service weight	kg	7010			
2.2		Axle loading, laden front/rear	kg	10810/1200				
2.3		Axle loading, unladen front/rear	kg	3160/3850				
TYRES, CHASSIS	3.1	Tyres: solid rubber, superelastic, pneumatic, polyurethane	pneumatic					
	3.2	Tyre size, front	300-15-18PR					
	3.3	Tyre size, rear	7.00-12-12PR					
	3.5	wheels, number front/rear	2X2					
	3.6	Tread, front	(mm)	1190				
	3.7	Tread, rear	(mm)	1130				
	DIMENSIONS	4.1	Tilt of mast/fork carriage, forward /backward	$\alpha / \beta$ (°)	6/12			
4.2		Height, mast lowered	(mm)	2250				
4.3		Free lift	(mm)	155				
4.4		Lift	(mm)	3000				
4.5		Height, mast extended	(mm)	4260				
4.7		Height of overhead guard(cabin)	(mm)	2250 (2400)				
4.8		Seat height/stand height	(mm)	1350				
4.12		Towing coupling height	(mm)	340				
4.19		Overall length	(mm)	4345				
4.20		Length to face of forks	(mm)	3275				
4.21		Overall width, std/dual	(mm)	1490/1924				
4.22		Fork dimensions ISO2331	(mm)	50/150/1070				
4.23		Fork carriage ISO 2328. Class/type, A/B		ISO 3A				
4.24		Fork carriage width	(mm)	1380				
4.31		Ground clearance, laden, below mast	(mm)	155/130				
4.32		Ground clearance, centre of wheelbase	(mm)	186				
4.33		Load dimension b 12*/6 crossways		1000x1000				
4.34		Aisle width with predetermined load dimensions	(mm)	4755				
4.34.1		Aisle width with pallets 1000 mm x 1200 mm crossways	(mm)	4885				
4.34.2		Aisle width with pallets 800 mm x 1200 mm crossways	(mm)	4885				
4.35	Turning radius	(mm)	2905					
4.36	Internal turning radius	b13	845					
PERFORMANCE DATA	5.1	Travel speed, laden/unladen	km/h	Shift 2: 25/27 Shift 1: 17/18	Shift 2: 22/24 Shift 1: 15/16	Shift 2: 25/28 Shift 1: 18/19	Shift 2: 26/28 Shift 1: 18/19	
	5.1.1	Travel speed, laden/unladen, backwards	km/h	Shift 1:19/20	Shift 1:17/19	Shift 1:21/22		
	5.2	Lifting speed, laden/unladen	mm/s	530/560				
	5.3	Lowering speed laden/unladen	mm/s	480/500				
	5.6	Max. drawbar pull laden/unladen	N	30000/23000	25000/21000	31500/30000	33000/32000	
	5.7	Gradeability, laden/unladen	%	20/25		21/25	20/25	
	5.9	Acceleration time, laden/unladen	sec	with load: 5.41(S1) / 5.06(S2) without load: 4.52(S1) / 4.35(S2)	with load: 5.24(S1) / 5.34(S2) without load: 4.82(S1) / 4.50(S2)	with load: 5.55(S1) / 5.19(S2) without load: 4.52(S1) / 4.35(S2)		
	5.10	Service brake		hydraulic				
	COMBUSTION-ENGINE	7.1	Engine manufacturer/type	Mitsubishi S6S	Kubota V3800-CR-TE5CB-HYM-1	Kubota WG3800-GL-C	Kubota WG3800-L-C	
		7.2	Engine power according to DIN ISO 1585	Kw	52	55.4	57.6	63.2
7.3		Rated speed	min-1	2300	2200	2400		
7.4		Number of cylinders/displacement	-/cm3	6/4996	4/3769			
7.5		Fuel consumption according to VDI cycle	l/h or kg/h	7.62 l/h or 6.4 kg/h	5 l/h / 4.2 kg/h	6.9 kg/h	7.44 kg/h	
7.6		Turnover output	t/h	345t/h	375t/h	346 t/h		
7.7		Energy consumption at turnover output	l/h or kg/h	9.97 l/h or 8.37 kg/h	8.93 l/h / 7.5 kg/h	8.46 kg/h	8.52 kg/h	
7.8		Generator	A	35	100			
7.9		Vehicle electrical system voltage	V	24	12			
7.10		Battery voltage/nominal capacity	V/Ah	2-12/60	12/120	12/90		
ADDITIONAL DATA	8.1	Type of drive unit	E-Hydraulic					
	10.1	Operating pressure for attachments	bar	195				
	10.2	Oil volume for attachments	l/min	70				
	10.4	Fuel tank capacity	L	100				
	10.7	Sound pressure level at the driver's seat	dB (A)	88	81.5	88		
	10.7.1	Sound power level during the workcycle	dB (A)	109.6	99.7	109.6		
	10.8	Towing coupling, type DIN		PIN				

# SPECIFICATIONS

MAST TYPE	Max fork lift	Overall extended height						Free lift				Load distance		Mast tilt		Capacity 500mm load centre Front single tyre			Mast weight	
		Lowered height		Without load backrest		With load backrest		Without load backrest		With load backrest		4.0-4.5T	5.0T	F	B	4.0T	4.5T	5.0T	4.0-4.5T	5.0T
		4.0-4.5T	5.0T	4.0-4.5T	5.0T	4.0-4.5T	5.0T	4.0-4.5T	5.0T	4.0-4.5T	5.0T									
		mm	mm	mm	mm	mm	mm	mm	mm	mm	mm	mm	mm	(°)	(°)	kg	kg	kg	kg	kg
2 STAGE LFL	3000	2250	2250	3850	3850	4260	4260	150	155	150	155	575	580	6	12	4000	4500	5000	1310	1325
	3300	2400	2400	4150	4150	4560	4560	150	155	150	155	575	580	6	12	4000	4500	5000	1335	1350
	3500	2500	2500	4350	4350	4760	4760	150	155	150	155	575	580	6	12	4000	4500	5000	1360	1375
	3700	2600	2600	4600	4600	5010	5010	150	155	150	155	575	580	6	12	4000	4500	5000	1370	1385
	4000	2800	2800	4850	4850	5260	5260	150	155	150	155	575	580	6	12	3800	4250	4750	1420	1435
	4500	3050	3050	5350	5350	5760	5760	150	155	150	155	575	580	6	6	3400	3800	4250	1490	1505
	5000	3300	3300	5850	5850	6260	6260	150	155	150	155	575	580	6	6	2800	3150	3500	1540	1555
	5500	3600	3600	6350	6350	6760	6760	150	155	150	155	575	580	3	6	2250	2800	2850	1630	1645
2 STAGE FFL	3000	2250	2250	3800	3800	4210	4210	1425	1425	1030	1425	585	590	6	12	4000	4500	5000	1420	1435
	3300	2400	2400	4100	4100	4510	4510	1575	1575	1180	1575	585	590	6	12	3960	4460	4960	1430	1465
	3500	2500	2500	4300	4300	4710	4710	1675	1675	1280	1675	585	590	6	12	3920	4420	4920	1470	1485
	3750	2625	2625	4550	4550	4960	4960	1800	1800	1405	1800	585	590	6	12	3850	4350	4850	1500	1515
	4000	2800	2800	4800	4800	5210	5210	1975	1975	1580	1975	585	590	6	12	3750	4250	4750	1540	1555
	4000	2110	2110	4860	4860	5260	5260	1270	1270	885	1270	630	635	6	6	3600	4000	4500	1760	1775
	4350	2235	2235	5210	5210	5610	5610	1395	1395	1010	1395	630	635	6	6	3400	3800	4250	1800	1815
	4500	2285	2285	5360	5360	5760	5760	1445	1445	1060	1445	630	635	6	6	3200	3600	4000	1820	1835
3 STAGE FFL	4800	2385	2385	5660	5660	6060	6060	1545	1545	1160	1545	630	635	6	6	3000	3350	3750	1860	1875
	5000	2485	2485	5860	5860	6260	6260	1645	1645	1260	1645	630	635	6	6	2800	3150	3500	1900	1915
	5400	2610	2610	6260	6260	6660	6660	1770	1770	1380	1770	630	635	3	6	2250	2550	2850	1940	1955
	6000	2850	2850	6860	6860	7260	7260	2010	2010	1625	2010	630	635	3	6	1700	1950	2200	2090	2105
	6500	3050	3050	7360	7360	7760	7760	2210	2210	1825	2210	630	635	3	6	1200	1500	1700	2240	2255

Capacities are with standard carriage.

ENGINE SPECIFICATION	mitsubishi 5.0L, DIESEL	KUBOTA 3.8L DIESEL	KUBOTA 3.8L LPG	KUBOTA 3.8L DUAL FUEL
	6 Cylinder overhead valve	4 Cylinder overhead Valve	4 Cylinder overhead valve	4 Cylinder overhead valve
	Displacement 4.996 litre	Displacement 3.769 litre	Displacement 3.769 litre	Displacement 3.769 litre
	Torque 250Nm @ 1,600rpm	Torque 308Nm @ 1,500rpm	Torque 300Nm @ 1,200rpm	Torque 300Nm @ 1,200rpm
	Power 52kW @ 2,300rpm	Power 55.4kW @ 2,200rpm	Power 63.2kW @ 2,400rpm	Power 57.6kW @ 2,400rpm
	Air filtration two-stage, dry type	Air filtration two-stage, dry type	Air filtration two-stage, dry type	Air filtration two-stage, dry type
	IDI fuel injection system			

## NOTICE:

Care must be exercised when handling elevated loads.  
Operators must be trained and must read, understand and follow the instructions contained in the Operating Manual.  
All values are nominal values and they are subject to tolerances.  
For further information, please contact the manufacturer.  
Hyster products are subject to change without notice.  
Lift trucks illustrated may feature optional equipment.  
Values may vary with alternative configurations.  
Specification data is based on VDI 2198.



# HYSTER® DEALERS



## HYSTER PACIFIC

1/23 Rowood Road, Prospect NSW 2145  
Tel: +61 (2) 9795 3800 Fax: +61 (2) 9792 8484

## HYSTER ASIA

16 Tuas Avenue 20, Singapore 638827  
Tel: +65 6863 3387 Fax: +65 6863 3349



© Hyster Asia Pacific 2022. All rights reserved. HYSTER,  and Strong Partners. Tough Trucks are trademarks of Hyster-Yale Group, Inc. Specifications and details in this brochure are subject to change without prior notification. Please consult with your Hyster dealer for the most up to date information and to confirm exact capacities.

**HYSTER.COM**

4530HBC4SP001\_E\_EN-SG\_V1R3\_102022

